







河南磨澳超硬材料有限公司
MORE SUPER HARD PRODUCTS CO.,LTD

-  www.moresuperhard.com
-  sales@moresuperhard.com
-  WhatsApp / Wechat: +86 13323855288
-  Zhengzhou · Henan · China



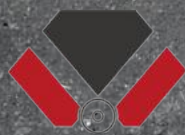

MORE SUPER HARD

**MORE
THAN
GRINDING**



用磨削

创造比磨削更多的
More than Grinding

价值

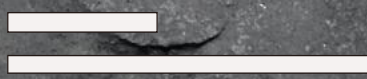

磨澳超硬

河南磨澳超硬材料有限公司
MORE SUPER HARD PRODUCTS CO.,LTD



公司简介 COMPANY PROFILE

磨澳超硬

始终致力于研发和生产更先进的金刚石以及CBN砂轮以提供给客户完善的磨削解决方案。我们先进的陶瓷，树脂，金属，混合结合剂以及电镀制品满足不同的磨削方式，平面磨，外圆磨，内圆磨，无心磨，仿形磨，周边磨，等..... 既适配于手动磨床，也适配于CNC加工中心。

用磨削创造比磨削更多的价值！

MORESUPERHARD

Devotes to develop and produce advanced diamond & CBN grinding wheels to provide you a complete grinding solution. With the advanced bond systems (Vitrified bond, Resin bond, Metal bond, Hybrid bond and electroplated), our products cover all grinding types, flat grinding, cylindrical grinding, internal grinding, centerless grinding, profile grinding, peripheral grinding, etc... Fit manual grinder and also CNC grinding center.

More than Grinding!



MORESUPERHARD

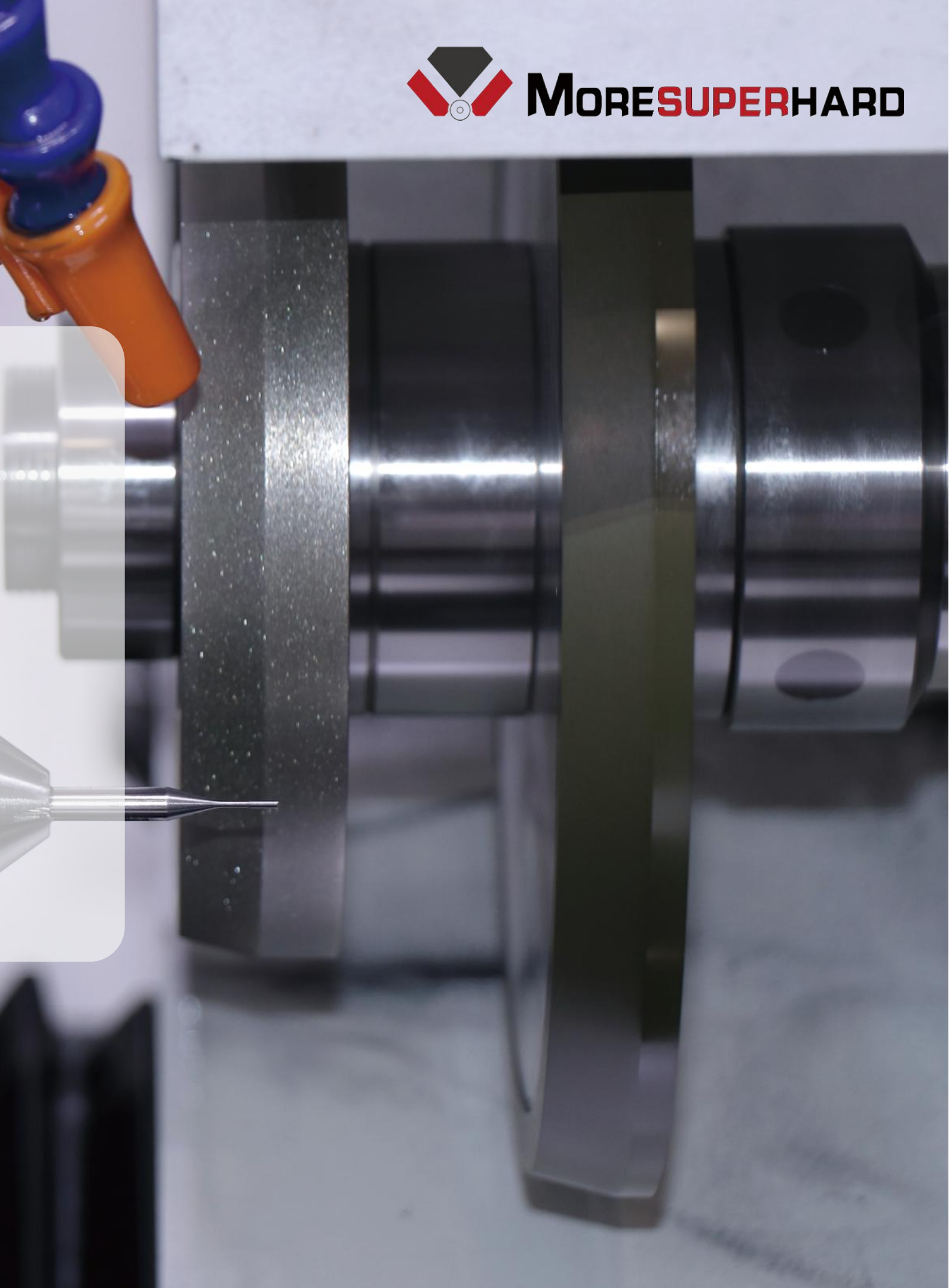

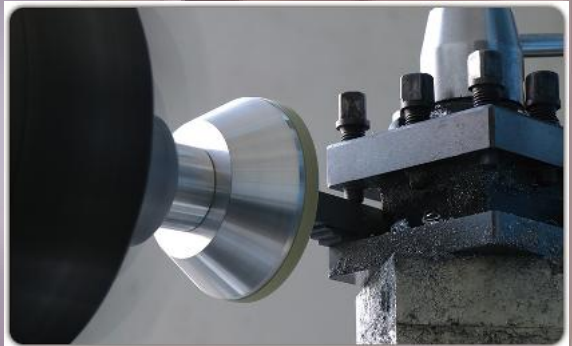
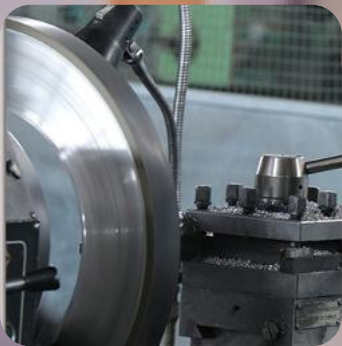
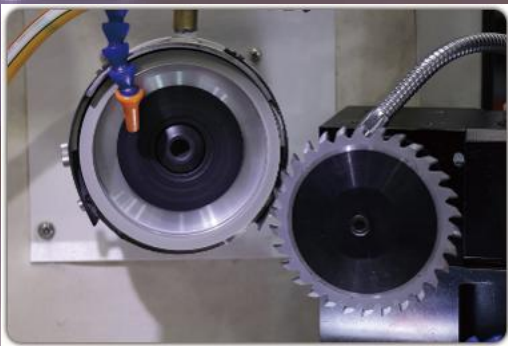

目录

Contents

5	Raw Material
7	Bond
9	PCD & PCBN Tools Grinding Solution
11	CNC Tools Grinding Solution
13	Woodworking Tools Grinding Solution
15	Semiconductor Solution
19	Cutting / Slotting Disc
21	Automotive Industry Grinding Solution
23	Grinding Mode
25	Automotive Industry Grinding Solution
27	Thermal Spray Coated Grinding Solution
29	Bearing Industry Grinding Solution
31	Ceramic Grinding Solution
33	Double Disc Grinding Solution
35	Free Grinding
37	Oil & Gas Industry Grinding Solution
39	Rotary Dresser
41	Grain Size Conversion Chart
42	Relationship Between Grit Size and Surface Roughness Hardness conversion table
43	Standard Wheel Shapes

Raw Material

We control the quality from the source of the diamond/CBN materials to select the most suitable material strength and shape for different bond and various application areas.



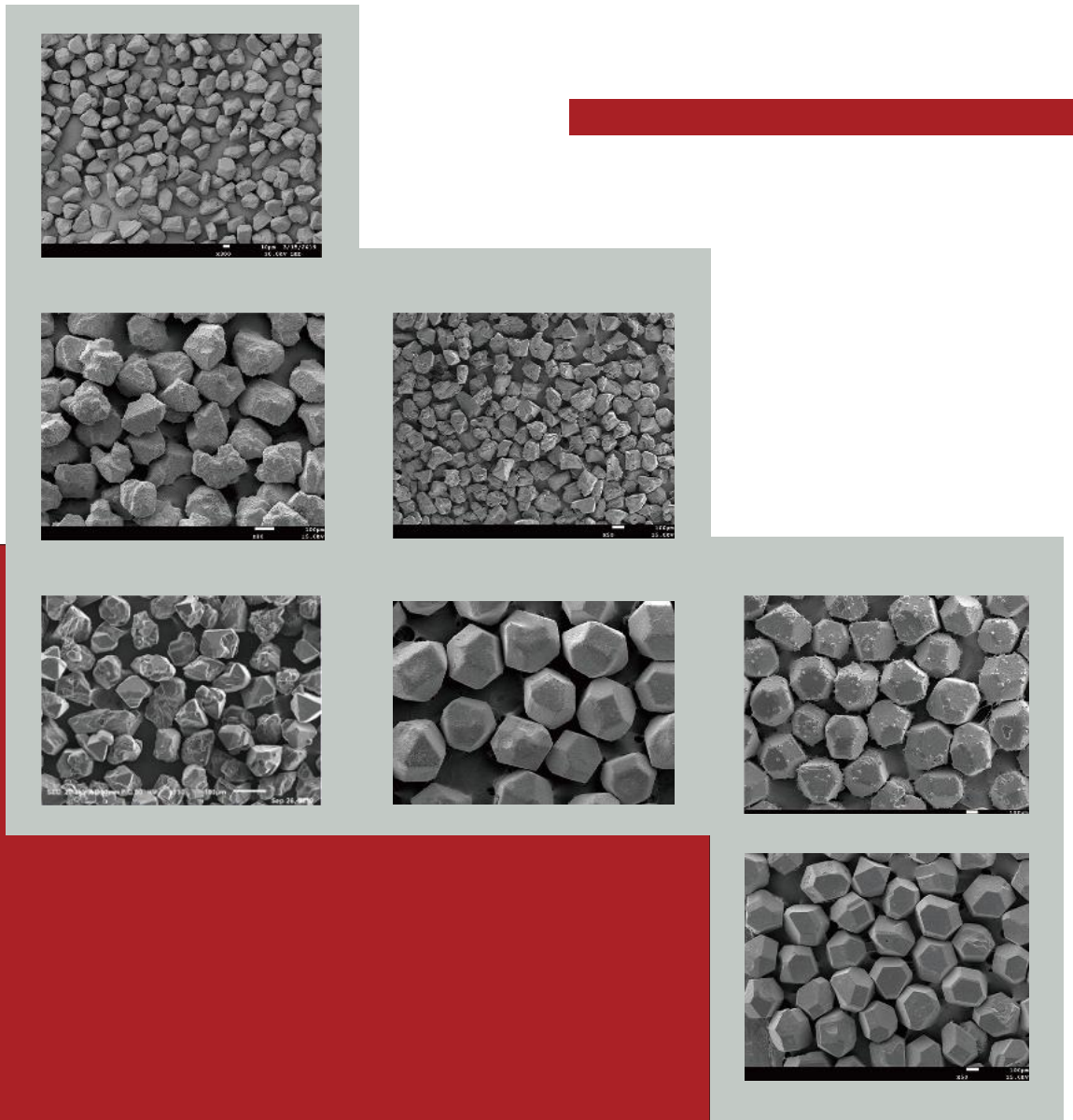

In MORESUPERHARD, every batch raw materials, especially for diamond powder, is inspected strictly. We do not only select the best diamond, but also select the right diamond which is perfectly situated for different application scenario.

Bond

The role of the bond is to help diamond and CBN to play different characteristics when dealing with different materials, so as to solve the grinding problem.

MORESUPERHARD offers resin bond, vitrified bond, metal bond, electroplated, hybrid bond, the complete bond agent gives you more choice to choose suitable product.





Resin Bond

- ▶ High surface finish.
- ▶ Fast stock removal.
- ▶ Easy to dressing.
- ▶ Wide range of applications.



Vitrified Bond

- ▶ Fast stock removal.
- ▶ Better form retention.
- ▶ Low wheel wear.
- ▶ Suitable for large grinding purpose.
- ▶ Easy to dressing.



Metal Bond

- ▶ Low wheel wear.
- ▶ Best form retention.
- ▶ Suitable for glass and stone.
- ▶ High shock resistance.



Electroplated

- ▶ Fastest stock removal.
- ▶ Shorter grinding times.
- ▶ Various shapes available.
- ▶ Suitable for one-time form grinding of precision parts.

PCD & PCBN Tools Grinding Solution

AGATHON, COBORN, EWAG, WENDT, WAIDA, and other grinding machines are specially used for carbide / PCD / CBN / Cermet inserts grinding. MORESUPERHARD supplies you vitrified bond and resin bond type grinding wheels which are fit to these grinders.

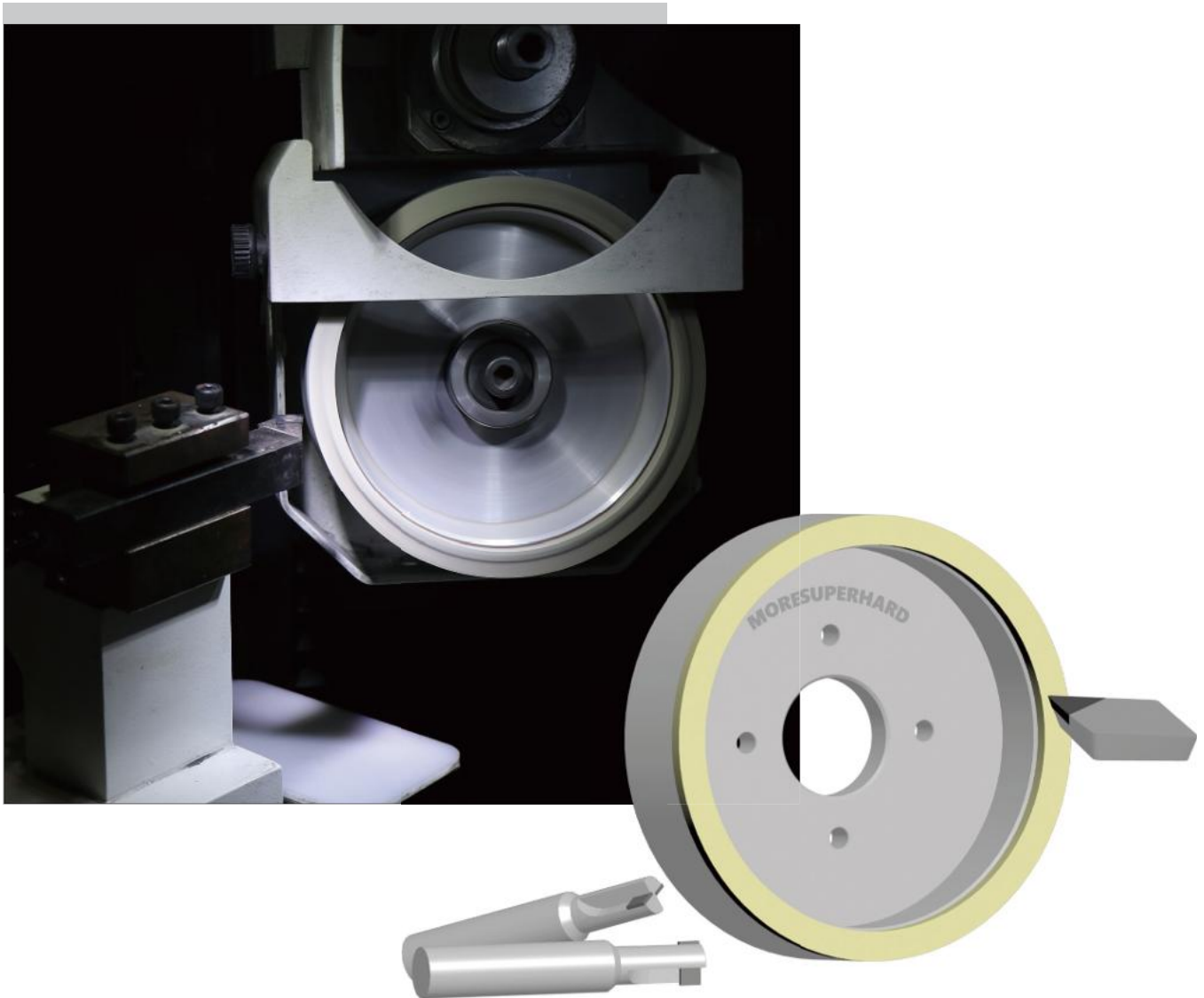

Grain size selection of vitrified diamond grinding wheel

Rough Grinding	400-500# (D35)	600# (D25)
Universal Grinding	800# (D20)	1000# (D15A)
Finish Grinding	1200-1500# (D15B)	2000# (D7)
Super Finish Grinding	2500-3000# (D5)	6000# (D2)
Ultra Finish Grinding	8000# (D1.5)	10000# (D1)

Vitrified bond diamond peripheral wheel can realize high-efficient grinding of PCD/PCBN inserts.



Resin bond diamond peripheral wheel can realize high-efficient grinding of carbide/ceramic/cermet inserts.



MORESUPERHARD team put metallic material in the resin bond to strengthen the grinding force. It solves the non-sharp phenomenon of general resin bond grinding wheels when grinding cermet inserts.



Dressing:

Dressing Stone

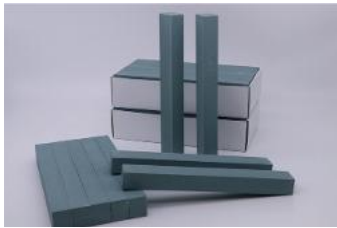

White Corundum Dressing Wheel



Special Diamond Dressing Wheel



- MORESUPERHARD special designed
- Incomparable dressing efficiency

CNC Tools Grinding Solution

Diamond and CBN wheels are available in resin bond and hybrid bond. The applicable machines include, Walter, Anca, Ewag, Vollmer, Rollomatic, Schutte, Schneeberger, Makino, TG-5, Studer, Strausak, Cincinnati, Griffo, Huffman, Jungner...

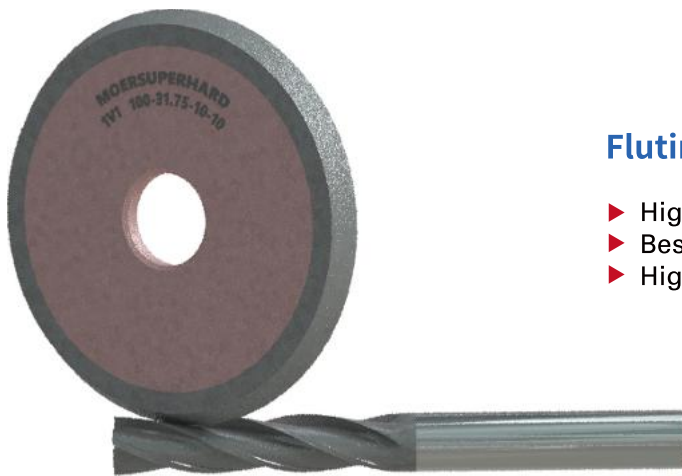

Fluting

- ▶ Higher stock removal rate reduces grinding time
- ▶ Best surface finish
- ▶ High edge retention

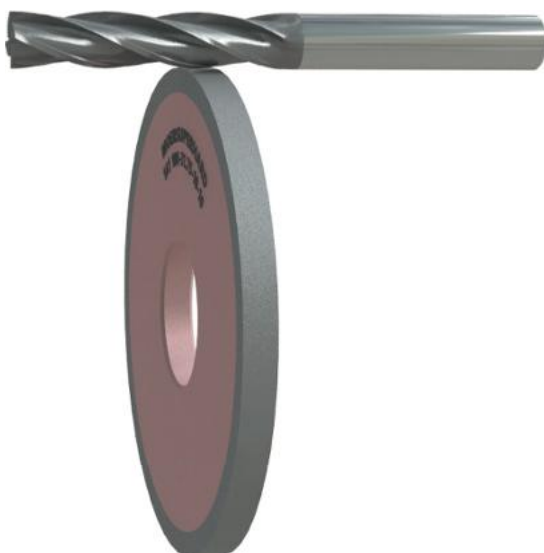

OD grinding

- ▶ Fast stock removal
- ▶ Shorter grinding times
- ▶ Reduced profile wear
- ▶ Easy to profile

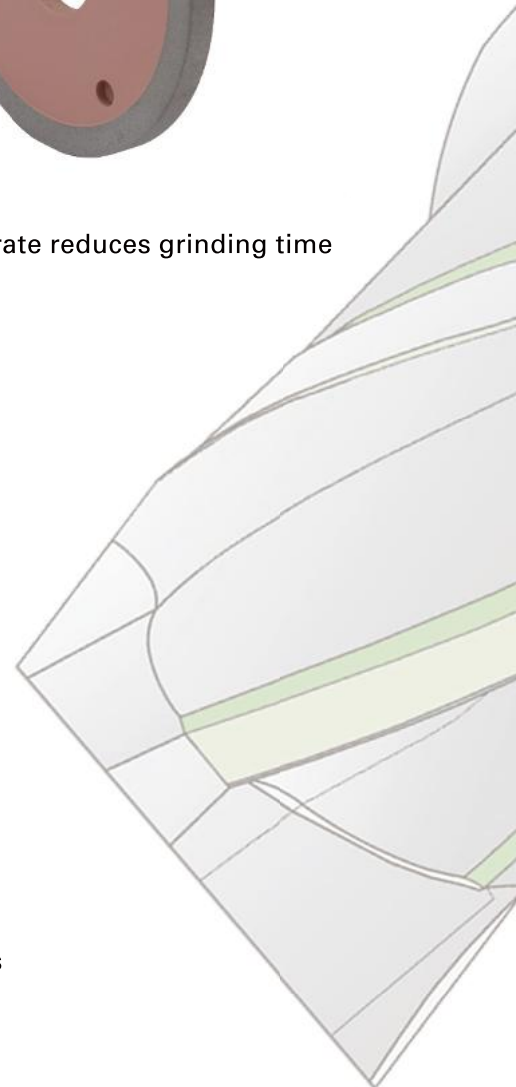

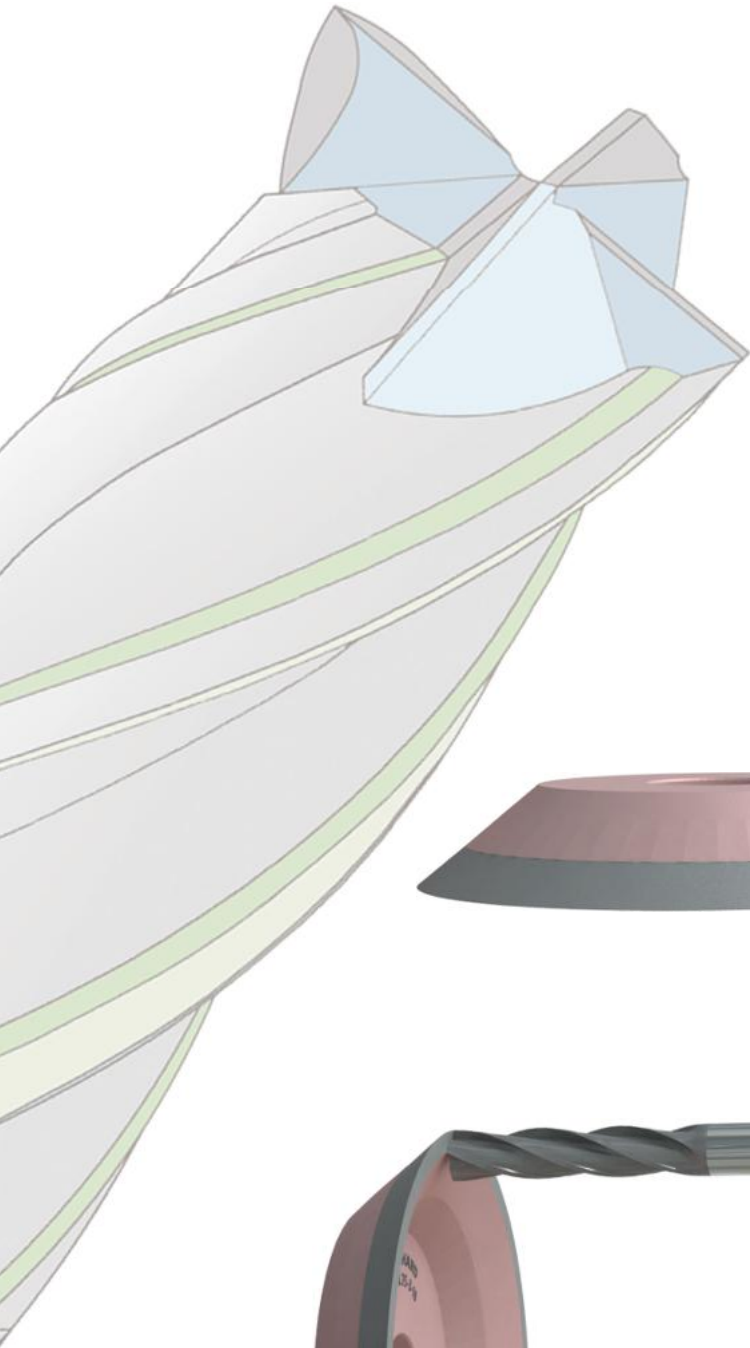

Gashing

- ▶ Good profile and corner stability
- ▶ Sharp wheel edge
- ▶ Fast cutting speed

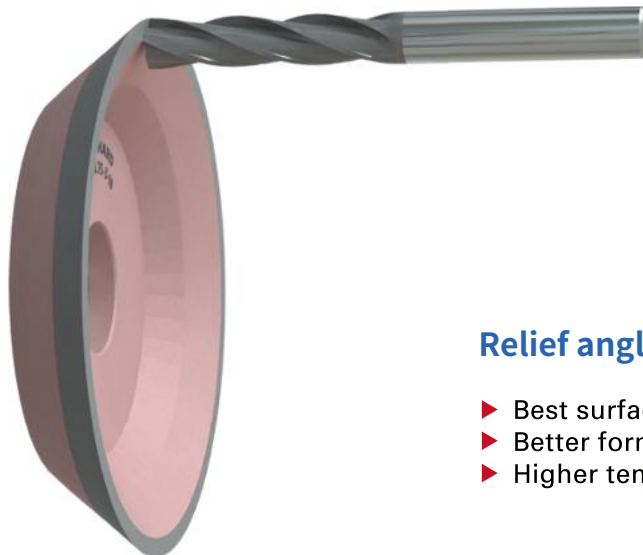

Relief angle grinding

- ▶ Best surface finish
- ▶ Better form retention
- ▶ Higher temperature operations

Woodworking Tools Grinding Solution

Get a satisfied grinding solution for your circular saws and band saws here. Whatever it is high speed steel, tungsten carbide, cermet or PCD saw, and whatever you want to grind tooth top, face, flank and side, MORESUPERHARD provides a full range of grinding wheels for woodworking tools grinding.

Carbide Circular Saw Sharpening

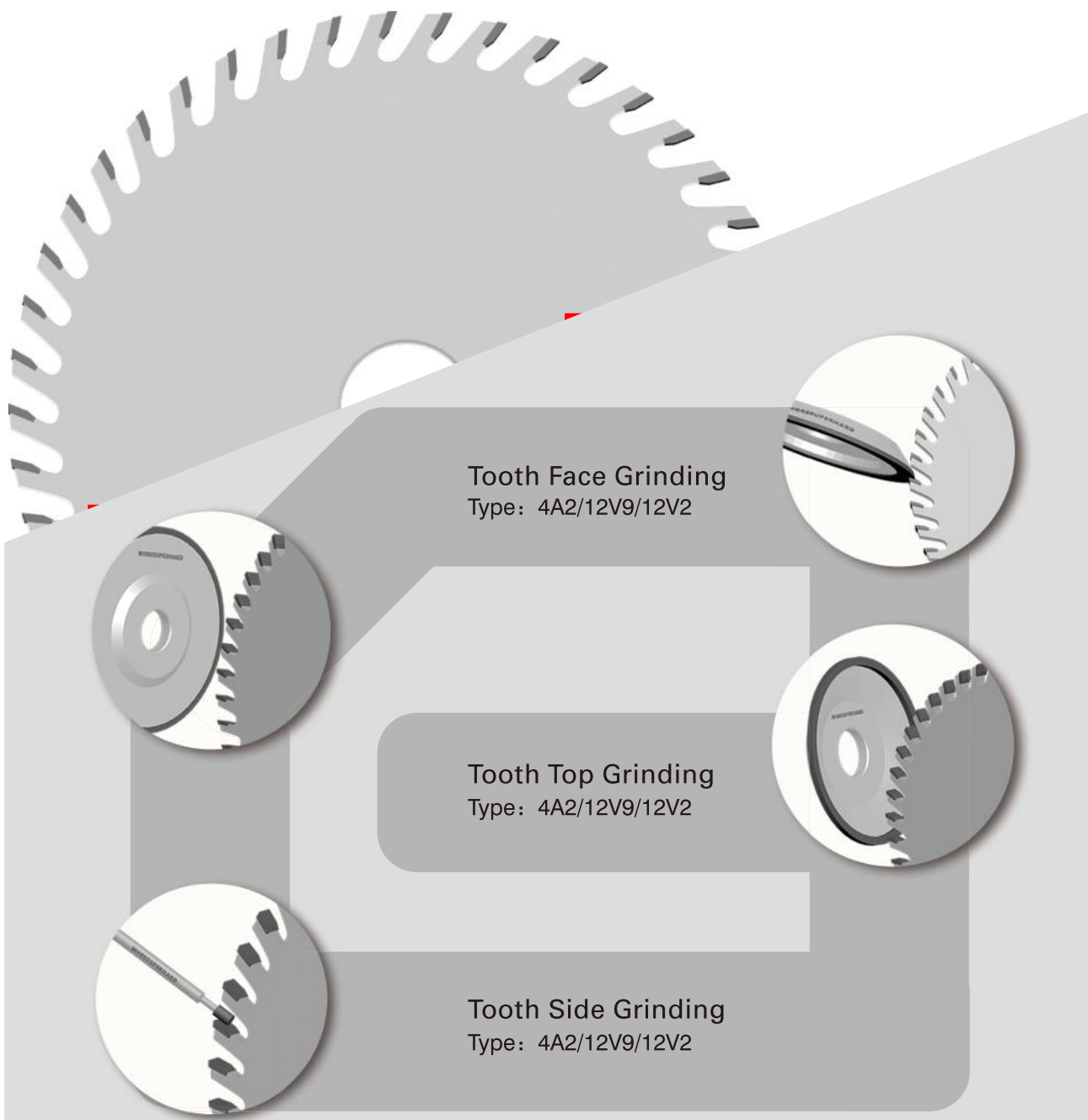



Chainsaw sharpening wheel

Tell us the pitch of your chain to choose the correct wheel.
Design your grinding wheels for chainsaw rakers grinding.



Main pitches

1/4 (6.35mm)
3/8 (9.5mm)
404 (10.2mm)

Wheels

5 3/4" (150mm)
4 1/8" (100mm)
8" (200mm)

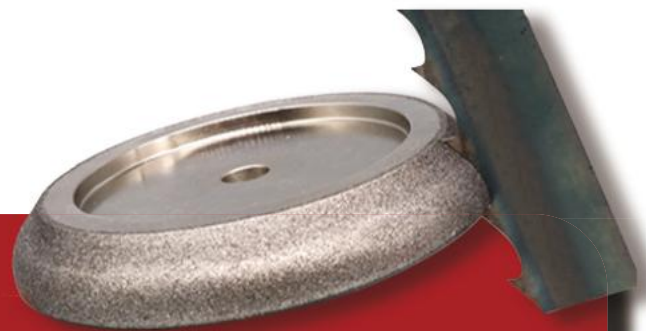
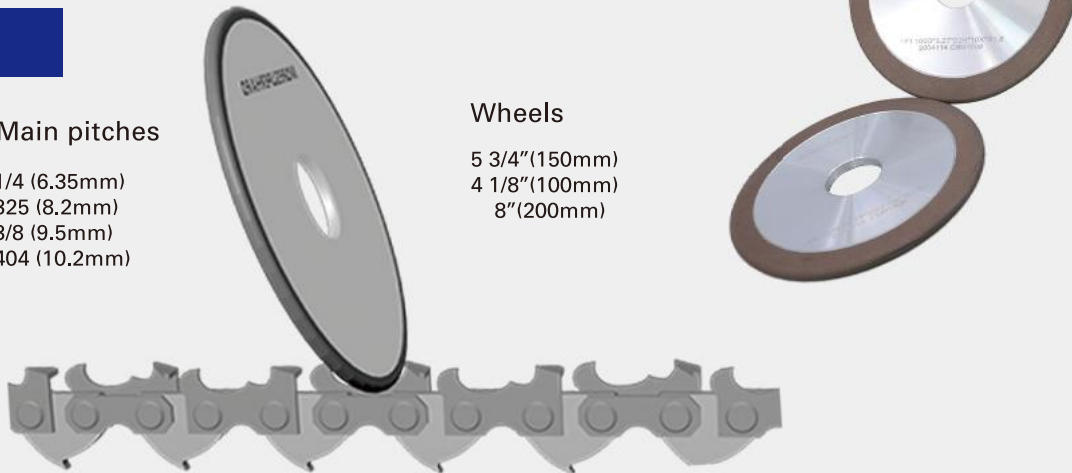

Band saw sharpening - CBN profile wheel

Different wheel profiles for all kind of wood and seasons are available

- * 10/30 - mostly used universal grinding wheel profile.
- * 9/29 - perfectly prepares band saws for winter time cutting, or cutting hard Wood.
- * 13/29 - wheel profile which prepares band saws for soft wood cutting.
- * 4/32 - wheel profile which can prepare band saws for very frozen and very hard wood cutting.
- * 7/34 - the CBN wheels profile is recommended for hardwood No need dressing.

Semiconductor Industry

MORESUPERHARD provides a line of premium dicing blades and accessories for semiconductor industry, also we can supply grinding wheels for silicon wafers thinning and flatting .

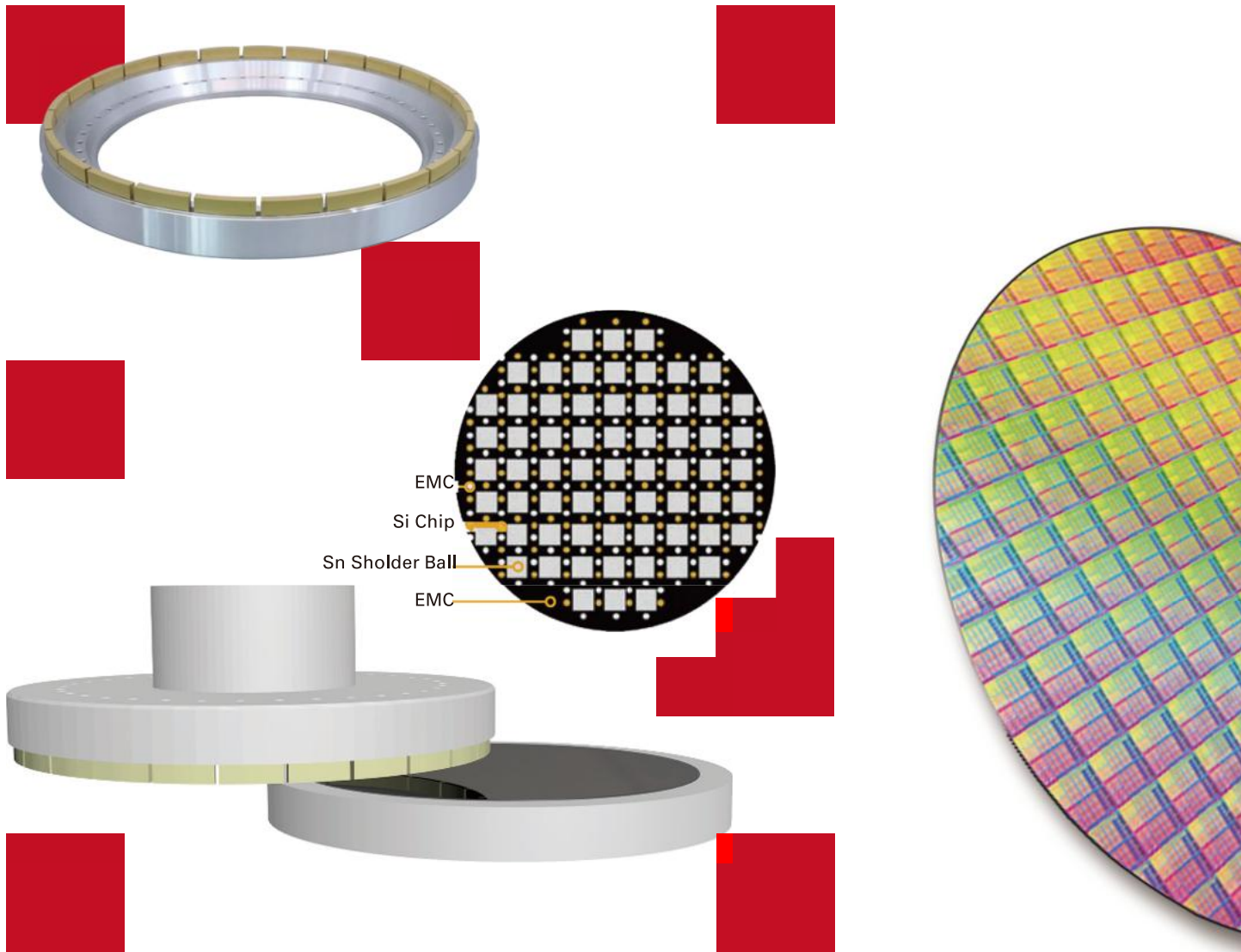

Silicon Wafer/Micro Chips Back Grinding Wheels

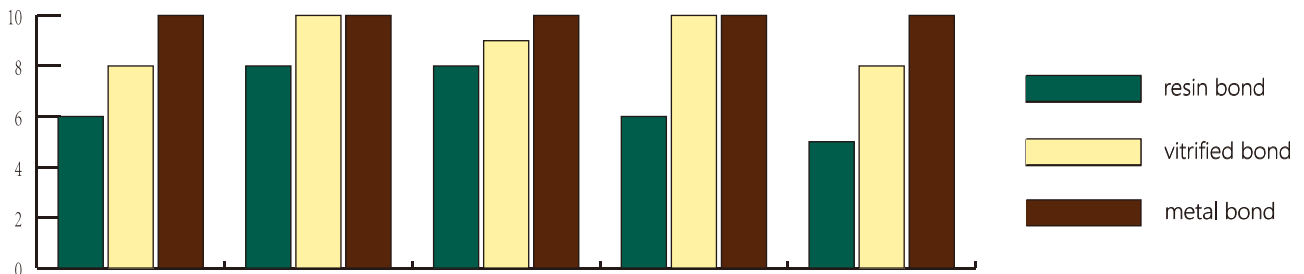



MORESUPERHARD

Electroformed Diamond Dicing Blade - Hub Type

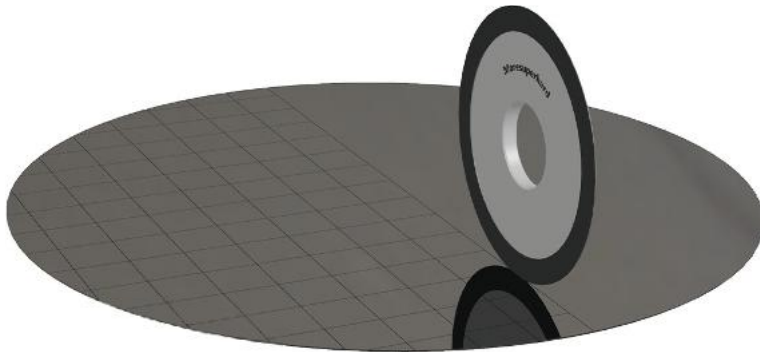

Hub blades which reduce stant cutting, blade damage, and wavy cutting.

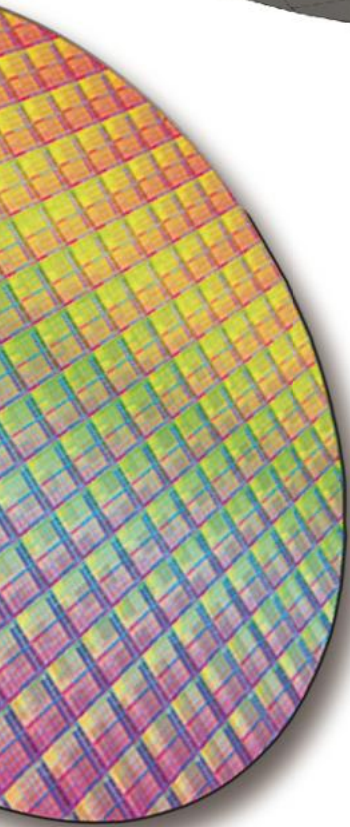

Hubless Dicing Blade

Resin bond blades for semiconductor packages such as QFN. Metal bond blades with improved cutting ability which still maintain rigidity.

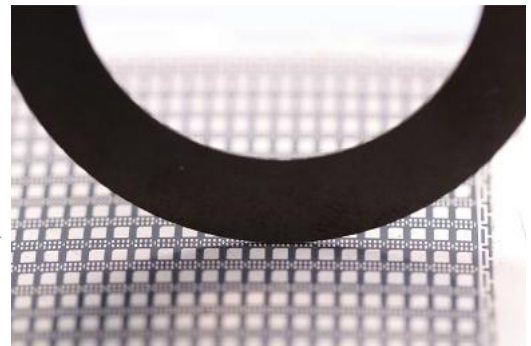
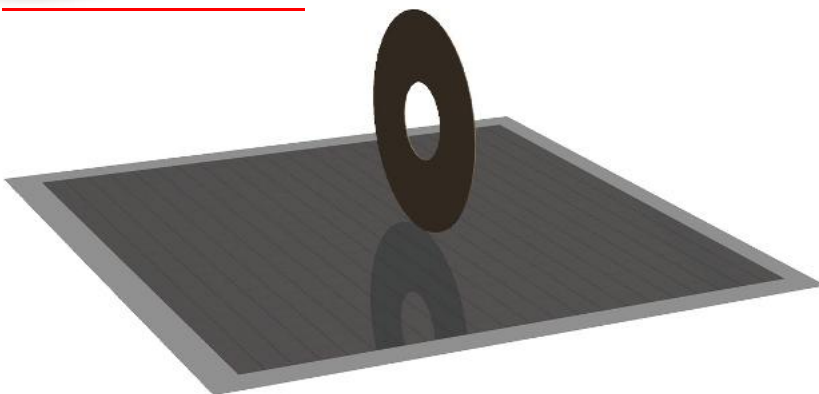

Diamond Wheels for Silicon Ingot

Metal/Hybrid diamond grinding wheel for silicon ingot cylindrical and orientation flat grinding.

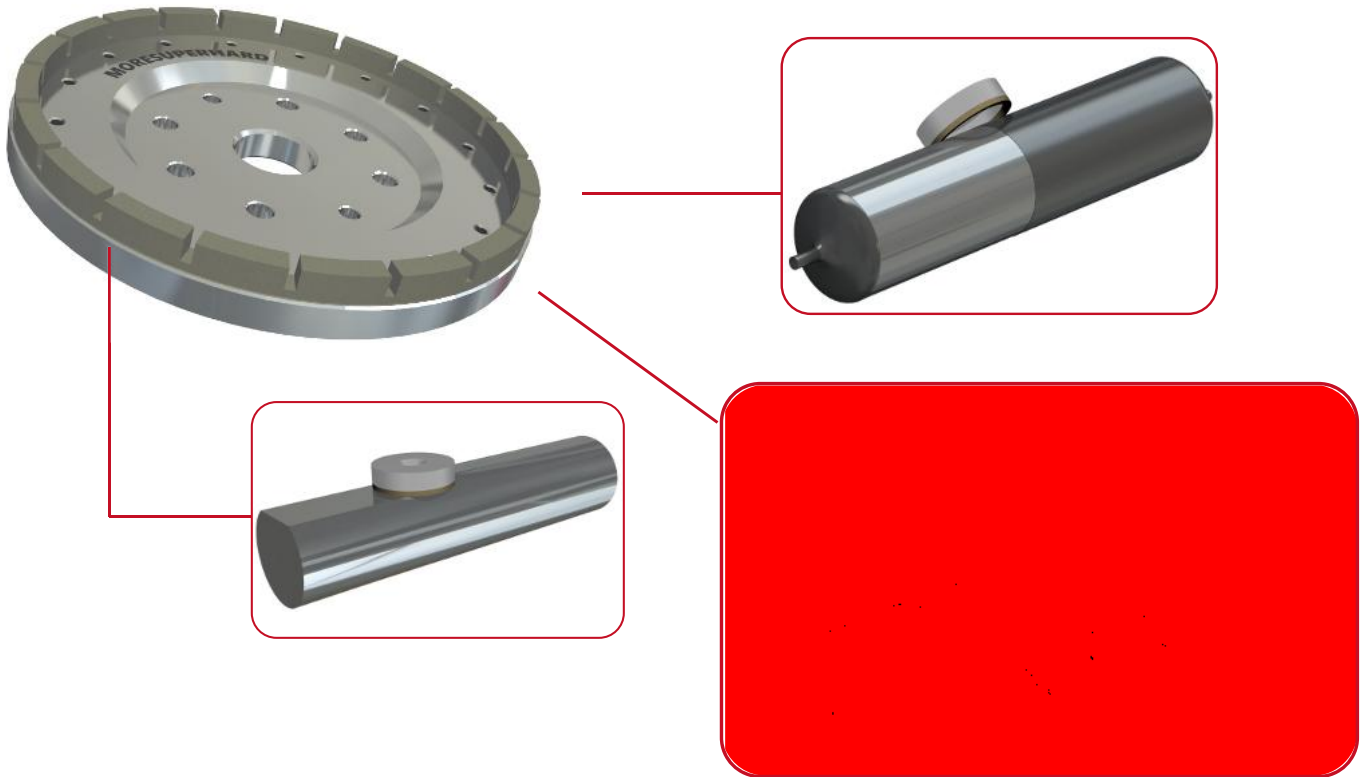

Wafer Chamfering Grinding Wheel

To achieve multiple grooves edge grinding with single metal/resin bond diamond grinding wheel. High precision, sharp and high wear-resistance make the grinding wheel more durable and stable.

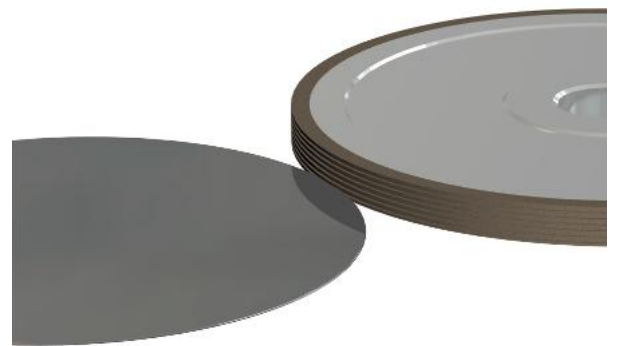

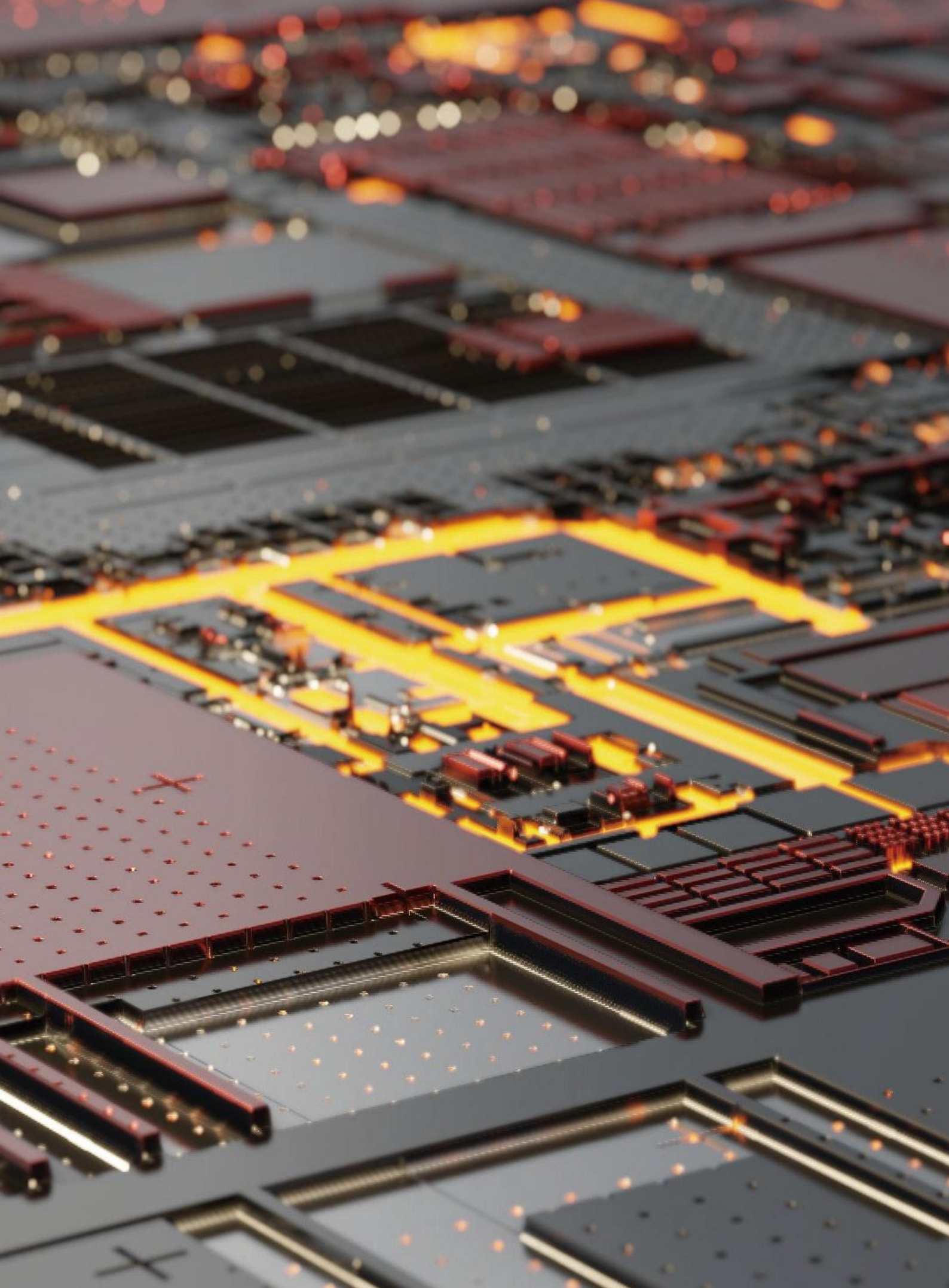

Cutting / Slotting Disc

Diamond cutting disc shows extremely high working life and superior sharp cutting ability. Whatever you want to cut ceramic, marble, glass, steel, carbide or carbon fiber, a diamond/CBN cutting disc helps you finish the work smoothly with high precision.



Resin bond :

Carbide, Ceramics, Carbon fiber ,
Plastics, HSS, Glass, Hardened Steel,
Gemstone

Choose resin bond if your work in a small infeed rate, and need a better cutting edge.

Metal bond :

Carbide, Ceramics, Plastics, HSS, Glass,
Hardened Steel, Gemstone, Marble,
Quartz.

Metal bond gives durable cutting ability and very good shape keeping.



Vacuum Brazed :

Marble, Cast iron, Steel, PVC pipe, Ceramics tiles

Vacuum brazed cutting disc is competent for heavy cutting work, it provides advantages of durable and sharp.



Electroplated :

Carbide, Ceramics, Plastics, HSS, Glass, Hardened Steel, Gemstone, Marble, Quartz, Carbon fiber, PVC pipe, Copper.

Electroplated is competent for complicated shape cutting. Be happy with its excellent sharp and highly customizable.

Automotive Industry Grinding Solution

MORESUPERHARD provides a complete solution for engine machining, and transmission components grinding in automotive industry.

We design and make special grinding wheels for cylinder block, cylinder head, crankshaft, camshaft, connecting rod, transmission case, gearbox shaft, clutch housing, and brake disc.

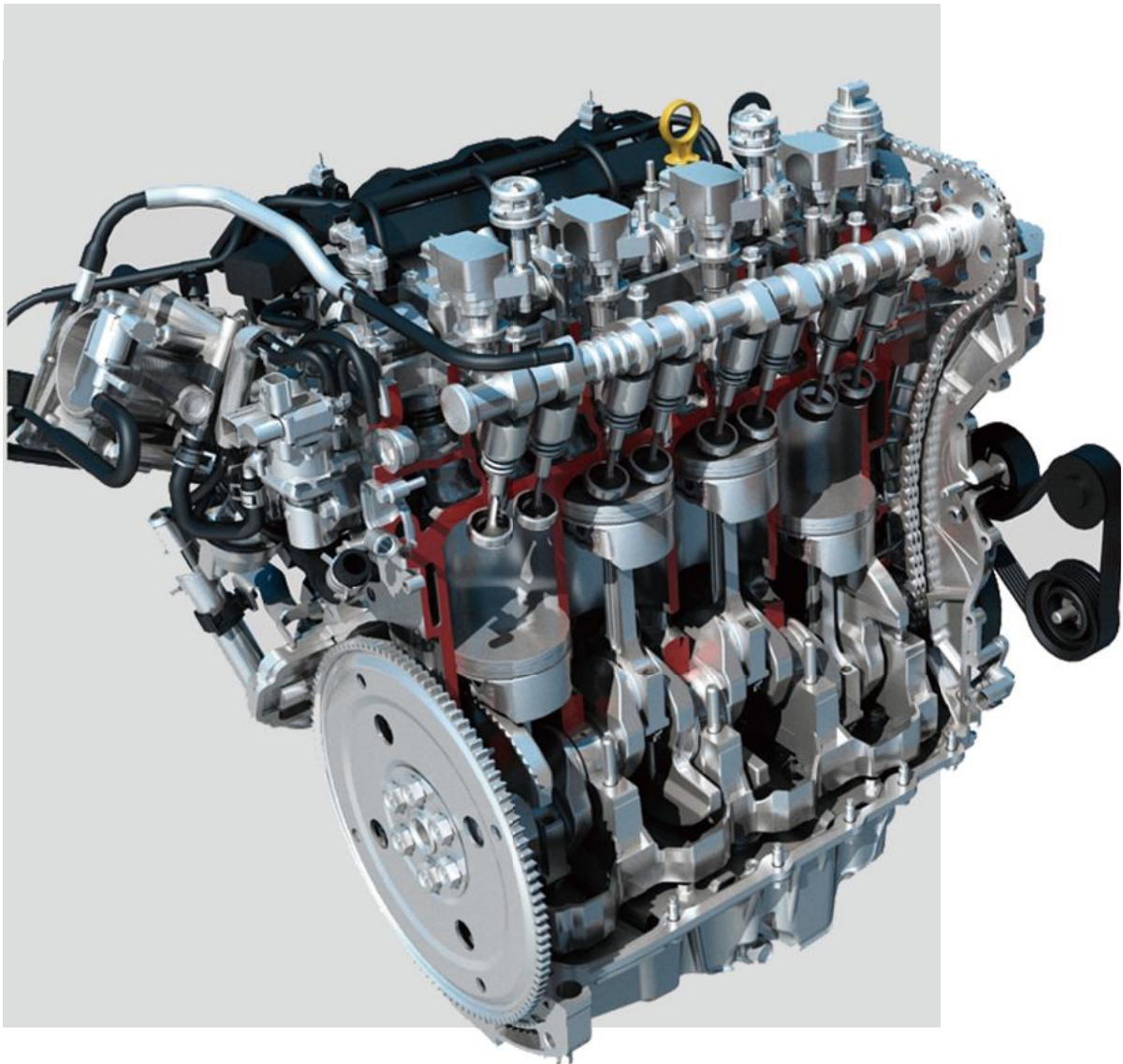

Fuel Injector Grinding

Grinding bore and seat face of fuel injection. The surface finish and dimensional requirements become more challenging due to the constant quest for improved fuel efficiency.

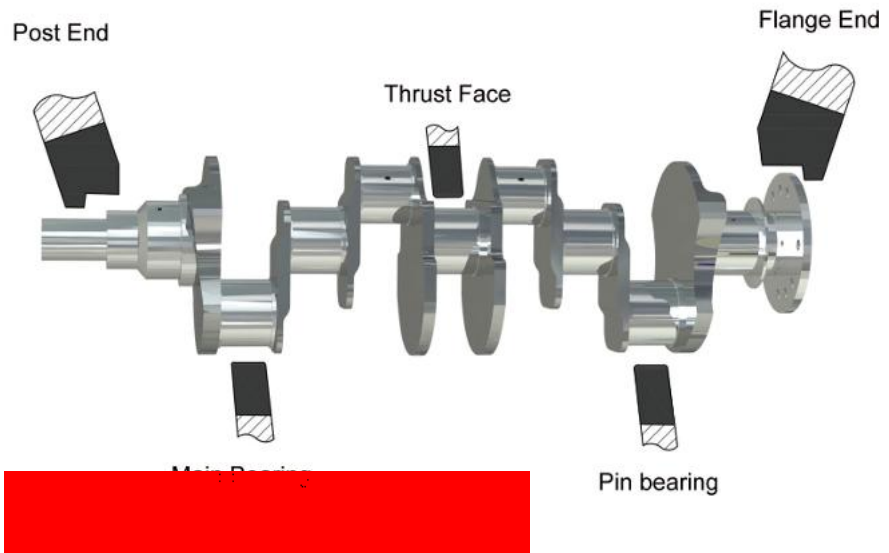

Crankshaft Grinding

- ▶ Main Bearing
- ▶ Rod Journals / Crankpin Journals
- ▶ Flywheel Flange End



- ▶ Camshaft main journals
- ▶ Cam (fixed on shaft)
- ▶ Cams (single)
- ▶ Camshaft lobe

Grinding Mode

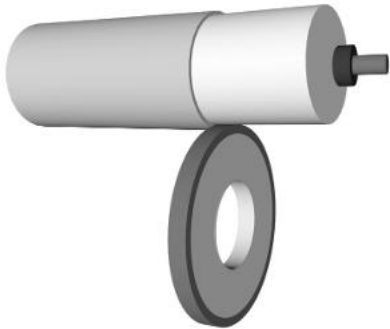

Cylindrical grinding

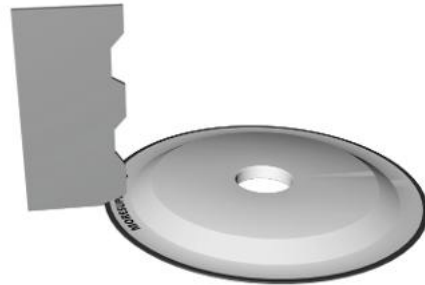

Optical profile grinding

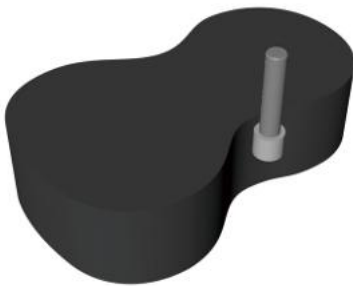

Jig grinding

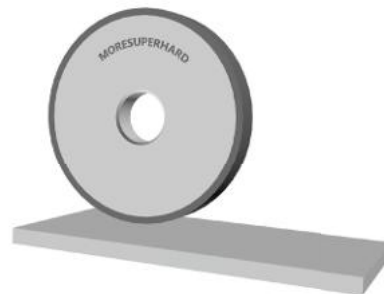

Flat grinding

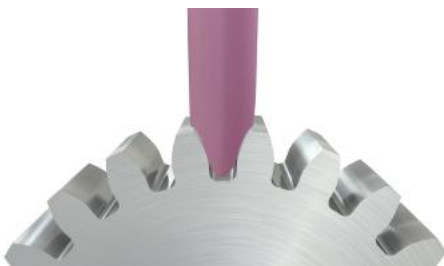

Profile grinding

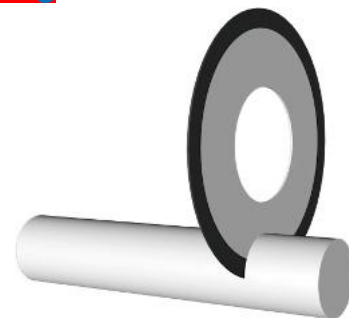

Cutting



MORESUPERHARD



Cutting edge grinding

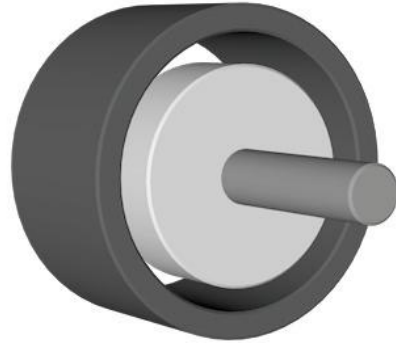

Internal grinding

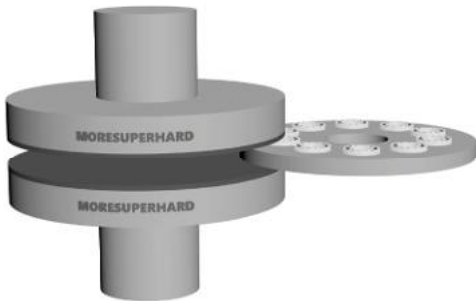

Double-face grinding



Honing



Dressing

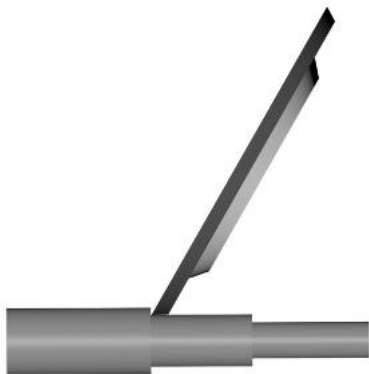

Step grinding

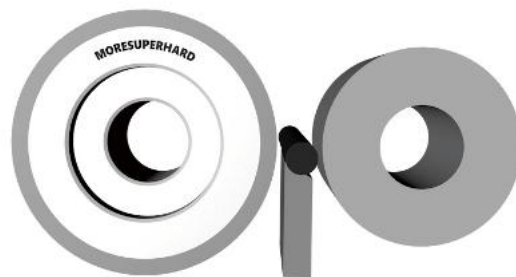

Centerless grinding

Automobile Industry Grinding Solution

Case1

Grinder	Toyota(JKT)	
Camshaft	Part	Cam lobe
	Material	GCr15
	Hardness	HRC58-62
	Working allowance	Diameter: 1.2mm
Parameters	Grinding speed	80m/s
	Roughness	Ra≤0.64
	Roundness	0.005mm
	TG	66"
Dressing	Tool	Sintered rotary
	Speed	60 m/s
	Allowance	0.005*4
Coolant	Oil	
Service life	~760 cam lobe/dressing	

Case2

Grinder	Junker	
Camshaft	Part	Camshaft journale
	Material	JB/t6397/EN10305- E355
	Hardness	HBS 207-302/HV10 210min
	Working allowance	Diameter: 0.9mm Rough grinding: 0.9mm - 0.1mm Finish grinding: 0.1mm - 0 mm
Parameters	Grinding speed	80m/s-120m/s
	Roughness	Ra≤0.2
	Roundness	0.005mm
	TG	90"
Dressing	Tool	CNC Reverse Plated Dressers
	Speed	70 m/s
	Allowance	0.003*6/7
Coolant	Oil	
Service life	~110 cam journale/dressing	

Engine Valve Grinding - Electroplated

- ▶ Valve cut off grinding
- ▶ Valve shaft centerless grinding
- ▶ Valve head & seat grinding
- ▶ Valve groove & tip radius grinding
- ▶ Valve stem end grinding
- ▶ Valve seat grinding

*No need dressing



Cylinder Block Honing - Diamond/CBN Honing Stones

- ▶ Removes excess metal stock
- ▶ Reinforces straightness, roundness and cylindricity
- ▶ Creates a crosshatch finish for optimal lubrication

*No need dressing

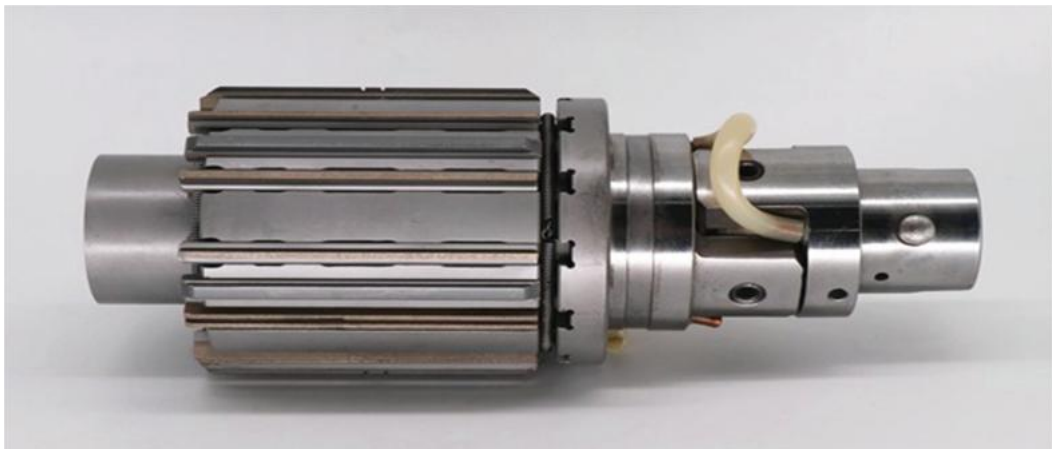

Thermal Spray Coated Grinding Solution

MORESUPERHARD provides a full range of thermal spray coating grinding wheels, include OD grinding, ID grinding, and polishing.

Cylindrical Diamond Wheel

Size:

- ▶ OD: 25-1100 mm (1-43 inch)
- ▶ Diamond ██████████



Diamond & CBN Flap Disc and Hand Pads

- ▶ Grit: 40#--600#
- ▶ Size: 4 inches, 4.5 inches and 5 inches, other size available on request
- *No need dressing

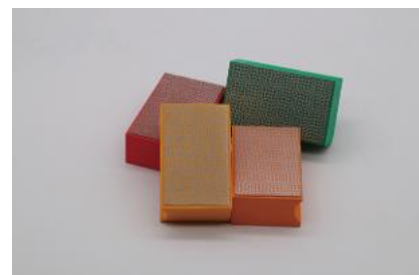
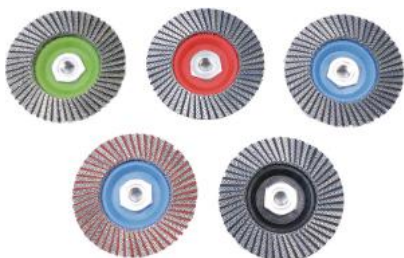

Diamond Sanding Belts

- ▶ Bond: Metal nickel plating electroplated bond & Resin bond (resin bond also consists of flexible and hard type)
- ▶ Length: 150mm - 5000mm
- ▶ Width: 5mm - 30mm
- ▶ Grit: 40# - 5000#



Diamond Micro-finishing Film — Electrostatic Sand Planting

- ▶ Rough grinding: 125 μ m, 74 μ m
- ▶ Fine grinding: 60 μ m, 45 μ m, 30 μ m, 15 μ m, 9 μ m

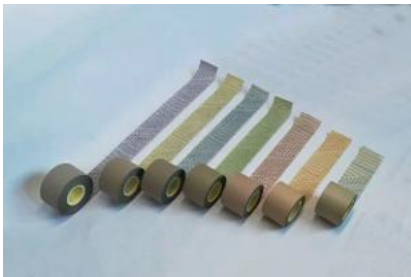

Bearing Industry Grinding Solution

Bearing is an indispensable part in mechanical equipment. MORESUPERHARD supplies a whole range of super hard tools for high efficiency, high precision grinding of bearing ring and bearing rotor.

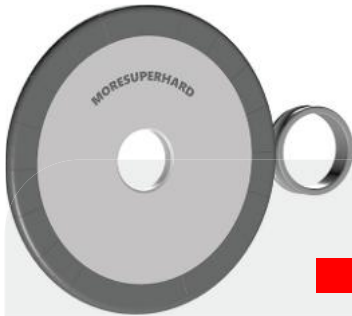

Outer & Inner Ring Internal Grinding

- ▶ Application
- ▶ Fast stock removal
- ▶ Reduce the thermal damage to the bearing
- ▶ Good form retention
- ▶ One-time form grinding of bearing

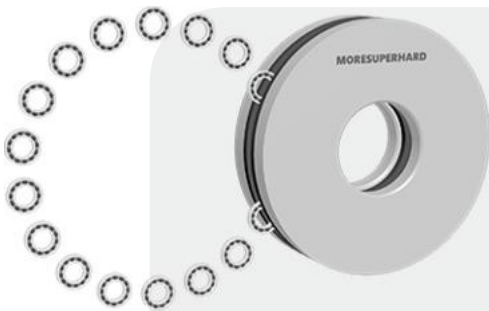

Face Grinding Wheel

It improves productivity by reducing cycle time. It's suitable for cost saving and quality improvement with longer life and better surface finish.

Bore Grinding

Grinding Condition

- ▶ Grinding speed: 30-80m/s
- ▶ Removal amount: 0.1-0.35mm

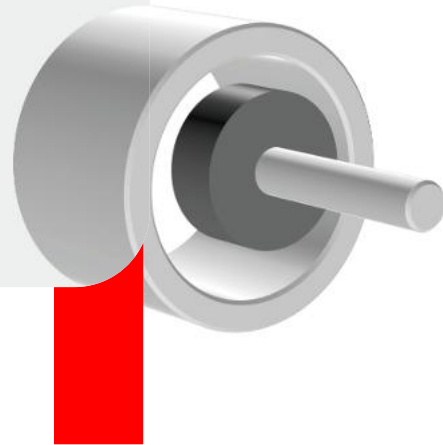

Diamond Rotary Dresser for Bearing Industry

Advantages

- ▶ High precision and complex grinding
- ▶ Less dressing load and excellent dressing performance
- ▶ Longer tool life and cycle time reduction
- ▶ Available for dressing of vitrified CBN wheel

Ceramic Grinding Solution

Most ground ceramic components have various types of surface or subsurface damage, due to the high hardness and brittleness of ceramic materials. This will lead to a reduction in strength of the ceramic components and limit the use of large material removal rates. The fundamental goal is to obtain the maximum material removal rate while maintaining surface integrity and dimensional accuracy of the material for high-efficiency ceramic grinding.

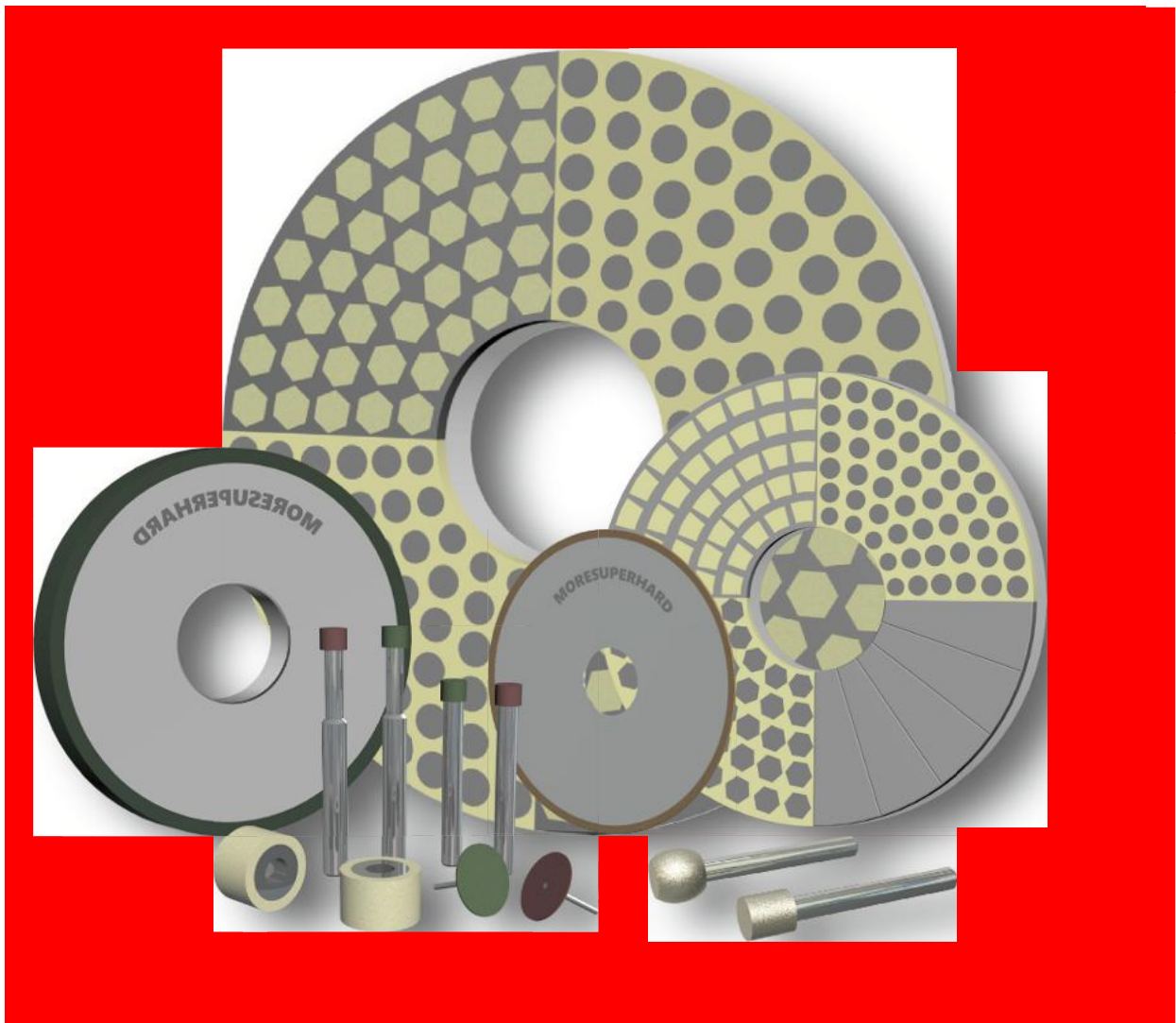

LED & Semiconductor Industry

The step of ceramic ferrule head is often scrapped due to the poor shape retention of the wheel during grinding.

MORESUPERHARD offers you a metal bond diamond wheel with excellent shape retention, it reduces the chance of a large arc formed by the step, improves production efficiency while reducing scrap rate.





Mechanical Seals

Silicon nitride ceramic seals are mainly used for dehydration equipment, refitted cars, test motors, refrigeration and air conditioning machinery and other equipments. Our diamond double disc can keep it sharp for a long time and less dressing time to ensure the stability of size in mass production.

Ceramic Knives

The grinding of ceramic knives requires the maximum material removal rate while maintaining the surface integrity and dimensional accuracy of the material. MORESUPERHARD selects sharp abrasives and strictly controls the size of abrasive particles to avoid mixing large grain, so as to solve the problem of easy scratches on the surface of ceramic knives and clogging of the grinding wheel during fine grinding.



Plunger Piston

Ceramic plunger has extremely high wear resistance, corrosion resistance and thermal impact.

The service life is 10-20 times longer than metal plunger.

We provide a variety of bond diamond centerless / cylindrical grinding wheels to meet your various grinding requirements.

Grit: 80 # - 5000 #



Double Face Grinding Solution

Double face grinding disc is good for brittle and precision parts' upper and lower parallel end faces grinding and polishing. It offers high quality of flatness, uniform thickness and roughness after grinding. That's why it has been widely used in optical and semiconductor industry.

MORESUPERHARD provides diamond & CBN grinding disc, suitable for single and double face grinding of steel, tungsten carbide, glass, ceramic, CBN and PCD.

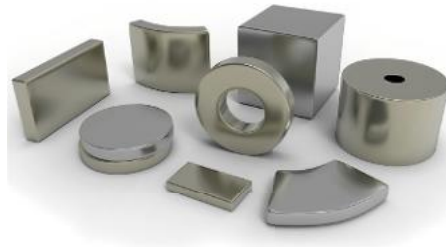

Magnetic substance



Compressor



Seal ring



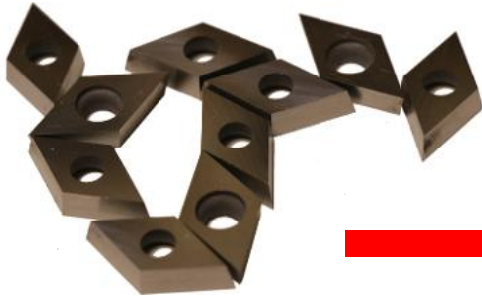

 inserts



Ceramic

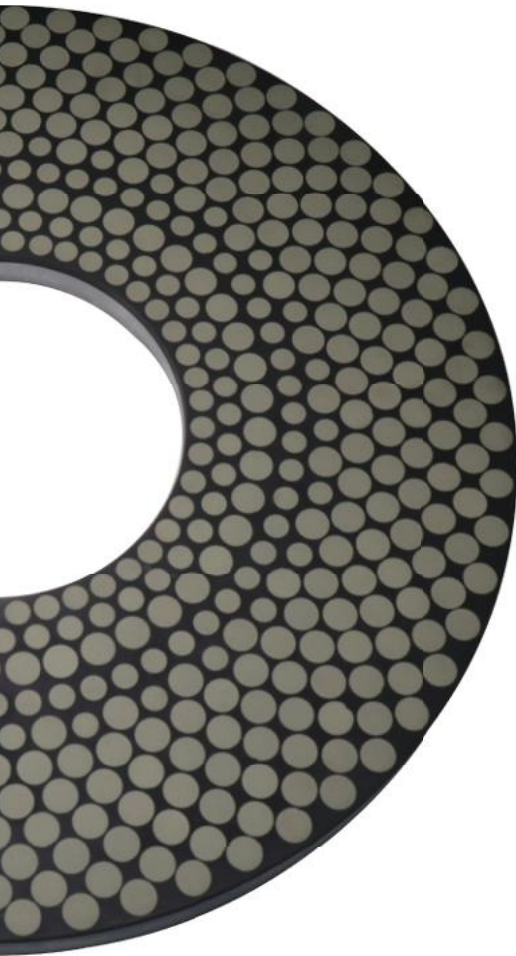

Connecting rod



Bearing



Mould

Free Grinding

Free grinding plays an important role in lapping, polishing and finishing process, you can get superior surface roughness with free grinding. We offer diamond polishing paste and diamond compound that the minimum grain size is 250nm. Reach mirror surface easily in jewelry, gems, knives, sapphire and silicon wafer polishing with our free grinding products.

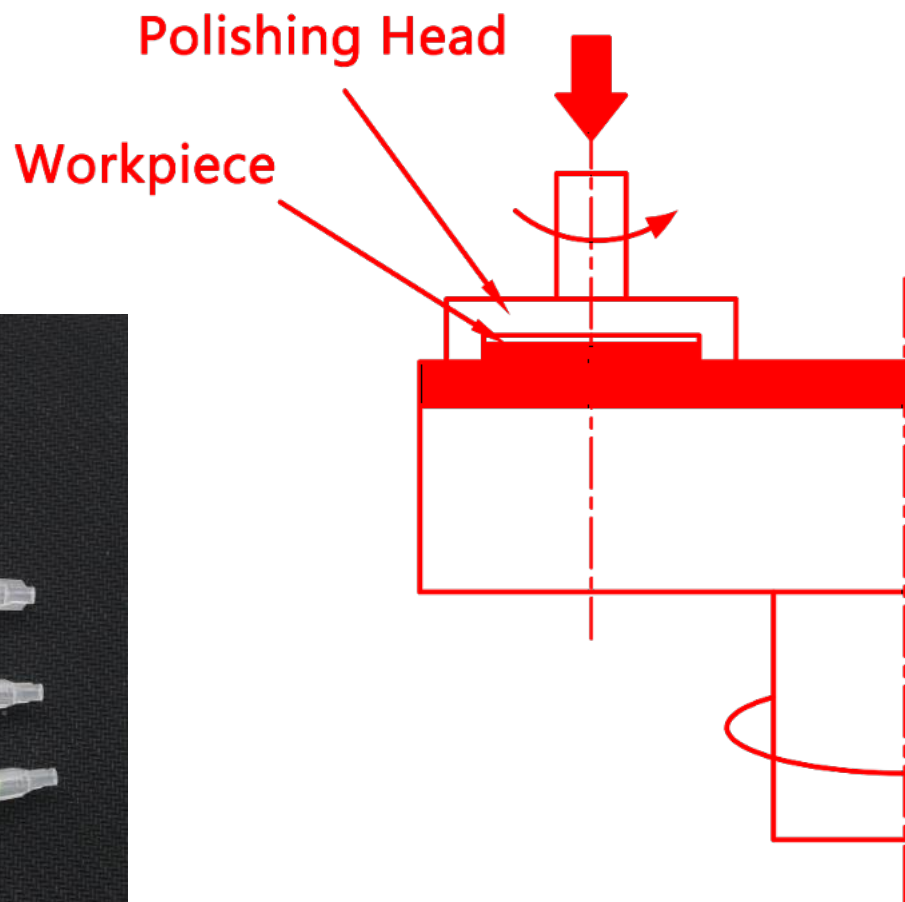

Diamond Lapping Paste

Strictly grit size grading
Sharp and high stock remove

Size: 0.25µm -- 400µm



Diamond Compound

Excellent suspension
 Polishing & lubrication & cooling "THREE-in-ONE"
 High polishing efficiency

Size: 0.25 μ m -- 400 μ m

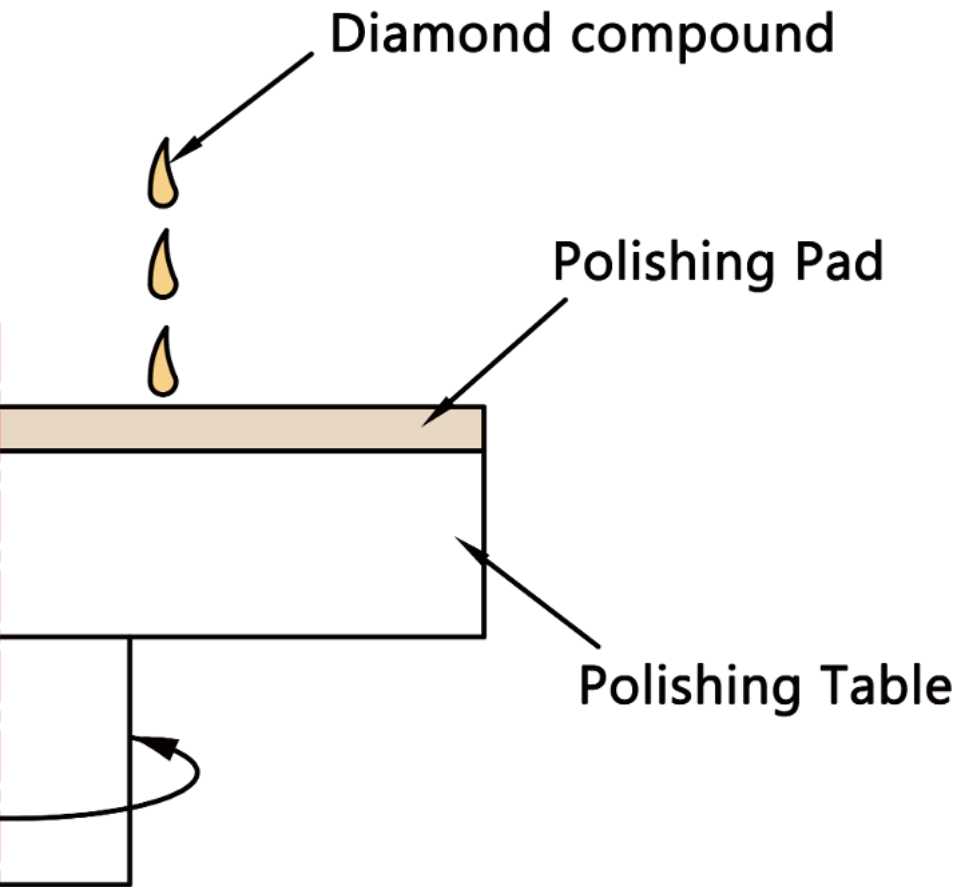

Polyurethane (PU) Polishing Pad

For optical glass, silicon carbide, sapphire substrate, precision ceramics polishing.

Good durability
 Stable and high polishing ability

Shape: rectangle, square, round

Size: 52" (maximum)

Oil & Gas Industry Grinding Solution

- Centerless Grinding on PDC and TC Cutters
- Chamfer and Size Grinding PDC and TC Cutters
- Gauge Grinding
- Hard Facing, Steel, Chrome and Alloy Materials Grinding
- Surface Grinding Gate Valves

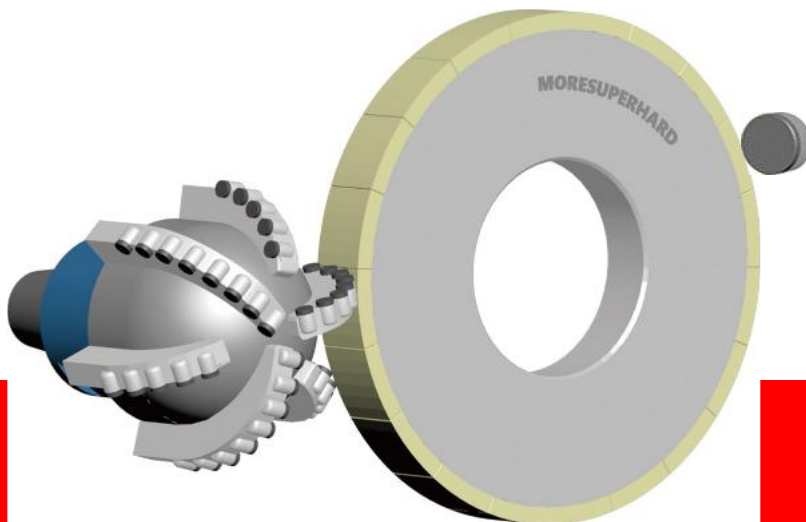

PDC Drill Bits Grinding

Vitrified bond diamond grinding wheel shows higher grinding efficiency in PDC cutter and PDC drill bits cylindrical grinding. It saves your 40% grinding time, and reduces 35% grinding cost. The dimensional accuracy of PDC drill bit is also improved.

Model	D(mm)	T(mm)	H(mm)	X(mm)
1A1	350	40	127	10
	400	40 50	203	10
	400	40 50	305	10

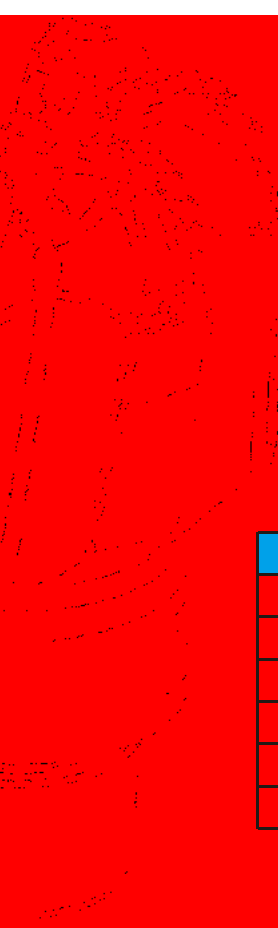

Resin bond Diamond Wheel for PDC Cutter / Drill Bits Grinding

Design and get any size resin bond diamond grinding wheel in PDC cutter and drill bits grinding. You can also grind the wear parts and gage protection part with this wheel.

D(mm)	D(inch)	H(mm)	T(mm)	X(mm)
400	16	127	25/50	10/25
500	20	127 203.2	25/50	10/25
600	24	254	25/50	10/16/25
750	30	304.8	50	10
914.4	36	304.8	25/50	10/25
1100	43	304.8	50	10

* Other specification can be made according to customer requirement

Rotary Dresser

Dressing with rotating diamond tools has been found to be a reliable technique in batch and performance grinding process. Especially for vitrified bond CBN grinding wheel's high precision dressing.

Rotary Dresser

Profile rotary diamond dressers are used to form grinding wheels for many different kinds of mass production.



Type of Profile Rotary Dresser

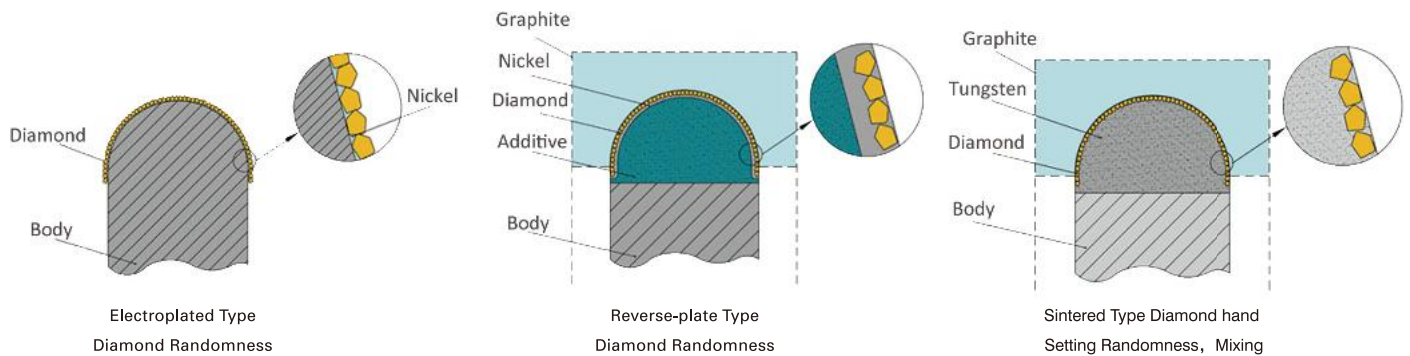

Description	Technology	Code	Diamond distribution	Diamond density	Accuracy of working surface
Profile rotary dresser	Sintered	SD	Hand Setting	Max	Middle
			Randomness	Max	Middle
Profile rotary dresser	Electroplated	ED	Randomness	Max	Low
Profile rotary dresser	Reverse-plate	RD	Hand Setting	Max	Middle
			Randomness	Max	High

Standard Forms

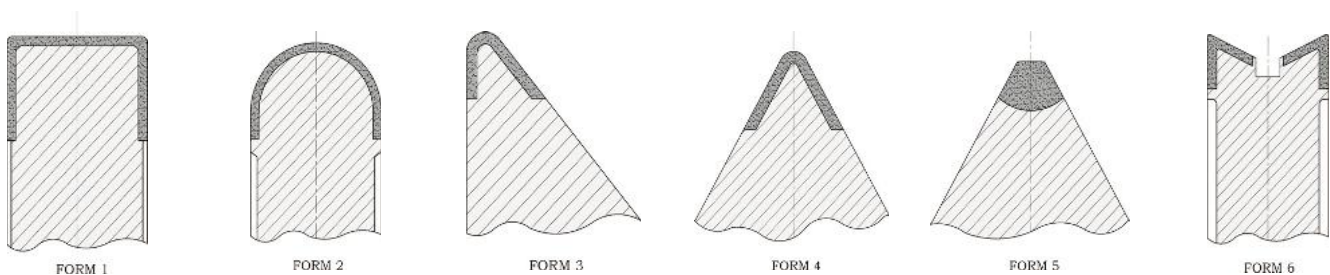

Dressing Disc

CNC dressing technique can be used in all fields of grinding production, especially for small and medium production lot sizes and for prototype applications. The profile of grinding wheel is created by CNC controlled process that moves rotating form roll along the target contour. Form rolls are therefore not restricted to a specific workpiece but can be used flexibly.

Type of Dressing Disc

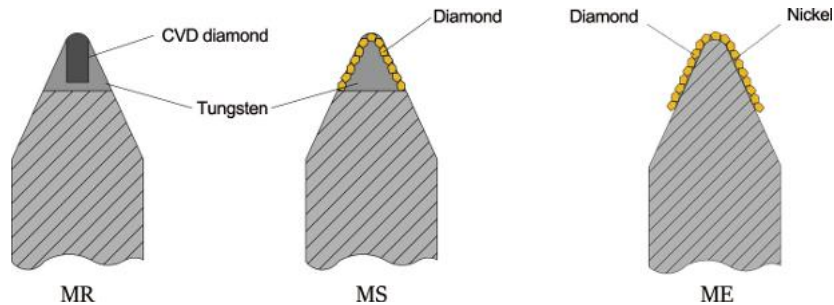

Description	Technology	Code	Diamond distribution	Diamond density
Dressing disc	Sintered	MS	Hand Setting	MAX
			Randomness	MAX
Dressing disc	Reverse-Sintered	MR	CVD	MAX
			Hand Setting	MAX
			CVD	MAX
Dressing disc	Electroplated	ME	Randomness	MAX

Diamond Rotary Dresser for Vitrified bond CBN Wheels Dressing

The primary characteristics of vitrified CBN grinding wheel are high hardness, high thermal conductivity, high sharpness, resulting in high grinding efficiency. Suitable for high efficiency grinding of steel.

Type of Diamond Rotary Dresser

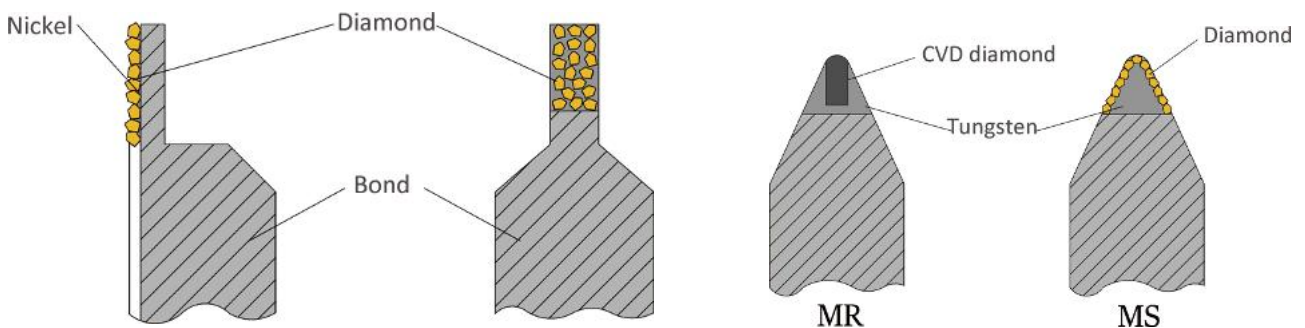

Grain Size Conversion Chart

MORSE SUPERHARD standard	CHINA		JAPAN		GERI	
	GRIT	SIZE	GRIT	SIZE	GRIT	SIZE
16/18 (20)	16/18	1000/1180	D1180	1000/1180	D1180	100/1180
18/20 (22)	18/20	850/1000	D1001	850/1000	D1001	850/1000
20/25 (24)	20/25	710/850	D851	710/850	D851	710/850
25/30 (30)	25/30	600/710	D711	600/710	D711	600/710
30/35 (36)	30/35	500/600	D601	500/600	D601	500/600
35/40 (40)	35/40	425/500	D501	425/500	D501	425/500
40/45 (46)	40/45	355/425	D425	355/425	D425	355/425
45/50 (54)	45/50	300/355	D356	300/355	D356	300/355
50/60 (60)	50/60	250/300	D301	250/300	D301	250/300
60/70 (70)	60/70	212/250	D251	212/250	D251	212/250
70/80 (80)	70/80	180/212	D213	180/212	D213	180/212
80/100 (90)	80/100	150/180	D181	150/180	D181	150/180
100/120 (100)	100/120	125/150	D151	125/150	D151	125/150
120/140 (120)	120/140	106/125	D126	106/125	D126	106/125
140/170 (150)	140/170	90/106	D107	90/106	D107	90/106
170/200 (170)	170/200	75/90	D91	75/90	D91	75/90
200/230 (180)	200/230	63/75	D76	63/75	D76	63/75
230/270 (240)	230/270	53/63	D64	53/63	D64	53/63
270/325 (280)	270/325	45/53	D54	45/53	D54	45/53
325/400 (320)	325/400	38/45	D46	38/45	D46	38/45
W40	M30/50	30/50	400	34/37	D35	32/40
	M30/40	30/40	500	28/34		
W28	M20/30	20/30	600	24/28	D25	25/32
	M15/25	15/25	700	20/24		
W20	M12/22	12/22	800	16/20	D20	25/30
	M10/20	10/20			D20A	
W14	M8/20	8/20	1000	13/16	D15	15/25
	M8/16	8/16			D15A	10/15
W10	M6/12	6/12	1200	10/13	D15B	15/20
	M5/10	5/10	1500	8/10	D15C	20/25
W7	M4/8	4/8	2000	6/8	D7	5/10
W5	M3/7	3/7	2500	5/6	D5	3/7
	M3/6	3/6	3000	4/5	D4	
W3.5	M2/4	2/4	4000	2/4	D3	2/4
W2.5	M1.5/3	1.5/3	6000	1.5/3	D2.5	1.5/3
	M1/3	1/3		1/3	D2	1/3
W1.5	M1/2	1/2	8000	1/2	D1	1/2
	M0.5/1.5	0.5/1.5	10000	0.5/1.5		
W1	M0.5/1.0	0.5/1.0	15000	0.5/1.0	D0.7	0.5/1
	M0/1.0	0/1.0		0/1.0	D0.5	0.5
W0.5	M0/0.5	0/0.5			D0.25	
W0.25	M0/0.25	0.0.25				

Relationship Between Grit Size and Surface Roughness

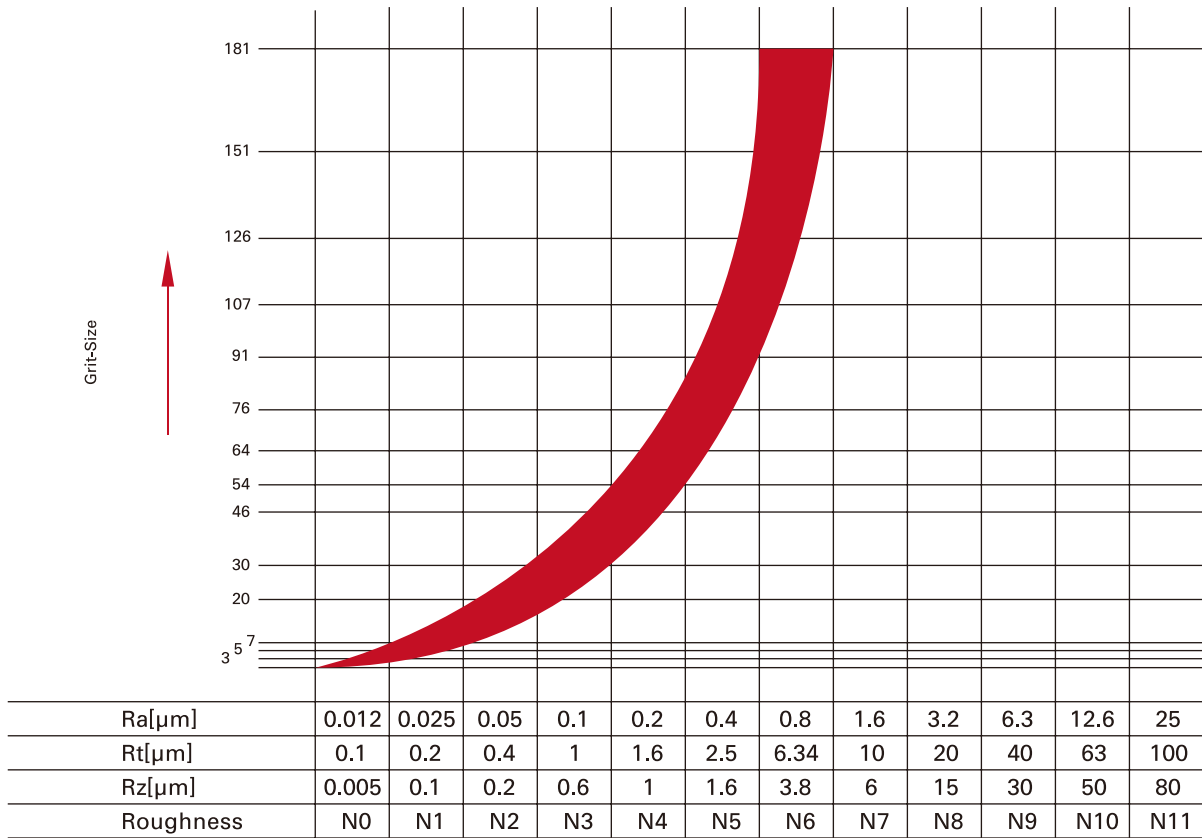

Hardness Conversion Table

Ra μm	Rt μm	Rz μm	Roughness Class
0.025	0.2	0.16	
0.05	0.4	0.32	N1
0.06	0.5	0.38	N2
0.08	0.6	0.5	↕
0.1	0.8	0.6	
0.12	1	0.75	N3
0.16	1.25	1	↕
0.2	1.5	1.25	
0.25	2	1.6	N4
0.31	2.5	2	↕
0.4	3.2	2.5	
0.5	4	3.2	N5
0.6	5	4	↕
0.8	6.3	5	
1.0	8	6.3	N6
1.25	10	8	↕
1.6	12.5	10	
			N7

Standard Wheel Shapes

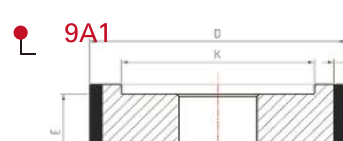
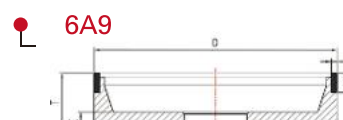
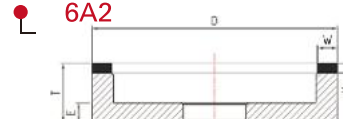
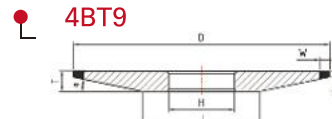
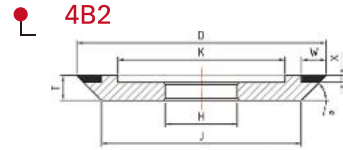
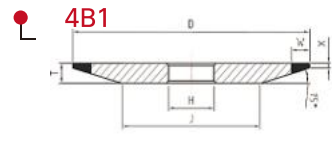
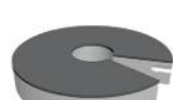
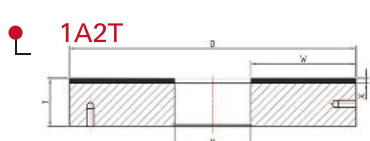
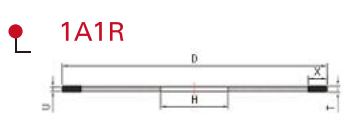
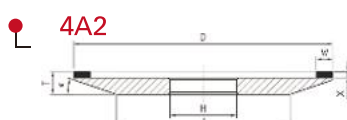
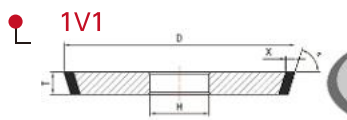
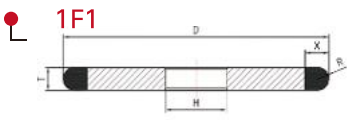
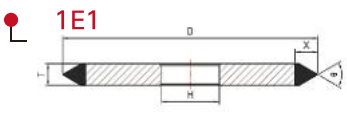
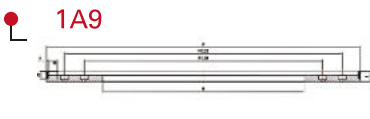
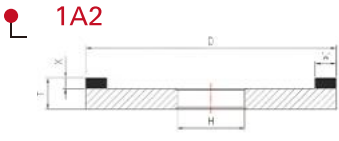
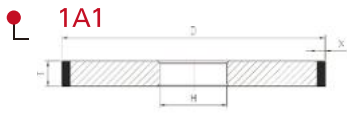

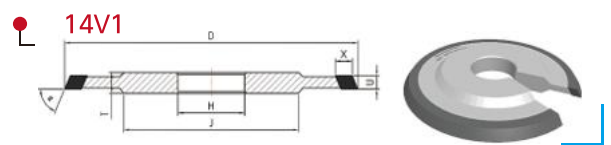
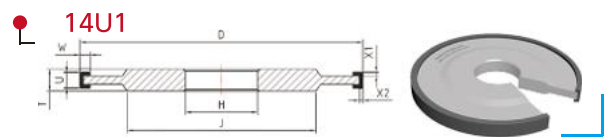
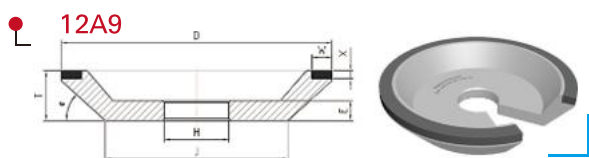
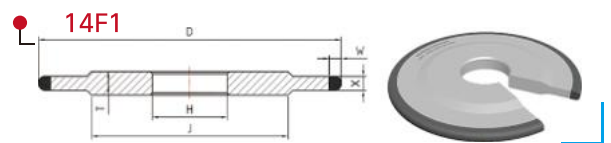
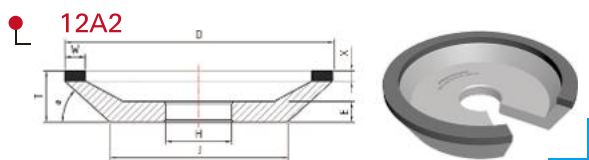
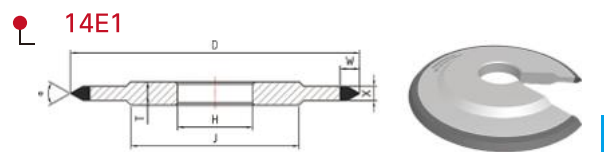
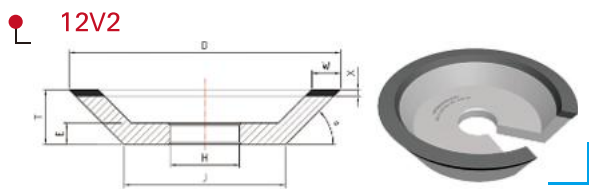
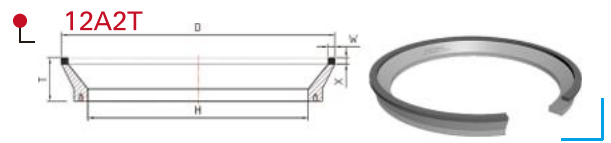
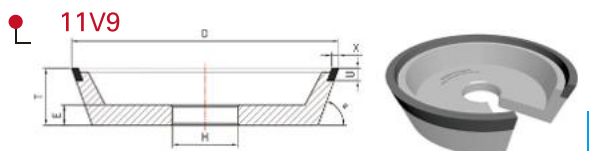
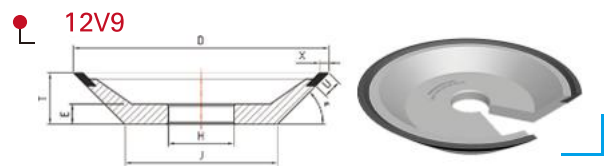
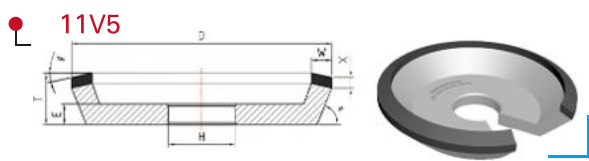
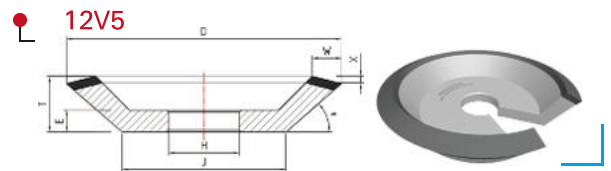
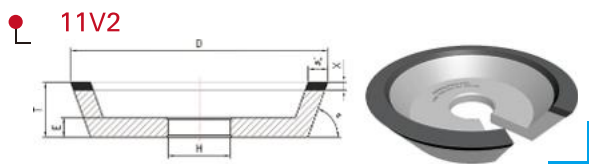
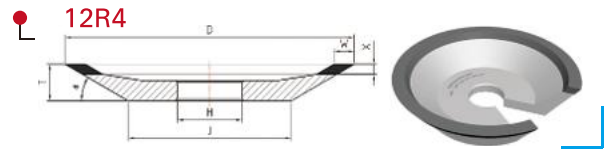
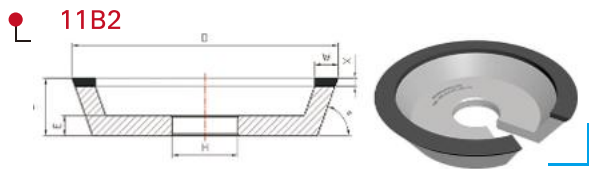
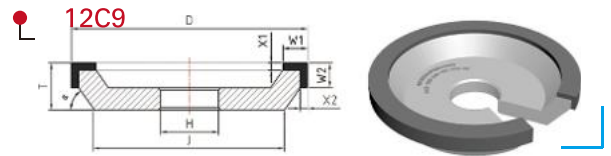
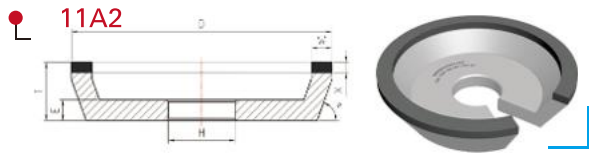

Grinding Questionnaire Form



Customer

Company Name:

City/Country:

Contact Person:

Tel/Mob:



Grinding wheel

Brand:

Size and Grit:

Max Linear Speed:

Using Linear Speed:



Grinding machine

Brand:

Grinding Type: Cylindrical Internal Surface Face Profile

Coolant Type: water oil emulsion

Spindle Capacity:

Other:



Work-piece

Name:

Roughness:

Material:

Grinding Allowance:

Hardness:

Rotation Speed:



MORESUPERHARD



MORESUPERHARD

www.moresuperhard.com





